



AWR-HT



0122 - 0302
34 ÷ 118 kW

High temperature and high efficiency reversible heat pump,
air source for outdoor installation



NEW!

(The photo of the unit is purely indicative and may vary depending on the model)

- Energy “class A” efficiency
- Maximum reliability
- Extensive range of operation
- Renewable energy for commercial installations
- Modular configuration



prana

CLIMAVENETA

SUMMARY

1. GENERAL DESCRIPTION	p. 3
2. MODELS AND VERSIONS	4
3. ADVANTAGES OF THE HEAT PUMP	5
4. SPECIFICATIONS	7
5. CONTROL ELECTRONICS	9
6. ACCESSORIES	10
7. GENERAL TECHNICAL DATA	11
8. COOLING CAPACITY PERFORMANCE	15
9. HEAT PUMP CAPACITY PERFORMANCE	17
10. DESUPERHEATER CAPACITY PERFORMANCE	19
11. OPERATING LIMITS	21
12. ETHYLENE GLYCOL MIXTURE	23
13. FOULING FACTORS	23
14. HYDRAULIC DATA	24
15. HYDRONIC GROUP (Optional)	25
16. ELECTRICAL DATA	32
17. LFULL LOAD SOUND LEVEL	33
18. DIMENSIONAL DRAWINGS	34
19. LEGEND OF PIPE CONNECTIONS	35



This company participates in the Eurovent Certification Programme. The products are listed in the Directory of certified products. Eurovent certification applied to units with cooling capacity up to 1500 kW for air cooled water chillers and water cooled liquid chillers.



Company quality system certified to UNI EN ISO 9001 and environmental certification UNI EN ISO 14001

Waiver of liability

This publication represents a preliminary document, and is the sole property of Climaveneta. Any reproduction or disclosure of such is strictly prohibited without the written authorisation of Climaveneta.

This document has been prepared with maximum care and attention paid to the content shown. Nonetheless, Climaveneta waives all liability deriving from the use of such document. Read this document carefully.

All work must be performed, components selected and materials used professionally and in complete accordance with the legislation in force in material in the country concerned, and considering the operating conditions and intended uses of the system, by qualified personnel.

The data contained in this publication may be changed without prior notice.

1. GENERAL DESCRIPTION

AWR-HT represent the best solution for systems in which there is the need to combine both high temperature water for space heating and sanitary purposes, as well as air conditioning. With this solution the space heating can be easily provided by using radiators, so without any major changes on the already existing distribution system available on site. The EVI technology compressor with additional steam injection in the compressing cycle assures a water temperature of 65°C and operating limits as low as -20°C. Neither probes nor connections pipes to wells are needed; the installation is simple, this is a suitable solution for all applications.

ENERGY 'CLASS A' EFFICIENCY

The full range is available with a premium efficiency rating, over the Class A. AWR-HT/CA-E and AWR-HT/LN-CA-E guaranty premium levels of efficiency and quietness, making this range the best solution for both residential and light commercial markets.

MAXIMUM RELIABILITY

AWR-HT offer maximum operating reliability, thanks to their two main features:

- two independent circuits for all sizes;
- system to prevent formation of ice on the coil, ensuring shorter and more efficient defrost cycles

EXTENSIVE RANGE OF OPERATION

Production of high temperature hot water up to 65°C for space heating and sanitary purposes. The unit can operate as standard down to -20°C outdoor temperature.

RENEWABLE ENERGY FOR COMMERCIAL INSTALLATIONS

Best solution in centralised residential systems such as apartment buildings, where the cost of renovation needs to be limited by keeping the same distribution system with radiators, while offering a source of renewable energy.

MODULAR CONFIGURATION

Modular configuration with capacity extension up to 400kW for medium- and high-capacity installations. Ability of managing different thermal loads according to the requirements of both heating and the domestic hot water systems.

CHILLED WATER PRODUCTION ONLY

The unit operates as a simple chiller and transfers the excess heat from the inside environment (heat of condensation) to the air via a finned coil heat exchanger.

The system water is cooled in a freon-water plate heat exchanger (evaporator).

HOT WATER PRODUCTION ONLY

The unit works as a heat pump that, by exploiting the heat of the source air via the finned coil heat exchanger, heats the water delivered to the distribution system via a freon-water plate heat exchanger (condenser).

COMBINED PRODUCTION OF HOT AND CHILLED WATER

If the systems require simultaneous production of chilled water and hot water for domestic use, the unit manages the changeover in operating mode from chiller to heat pump and deviates the flow of water to the two separate systems via a three way valve, based on the priority assigned.

Changing the operating set point ensures the correct water production temperature for the different uses.

Suitable storage tanks can be used for both chilled and hot water to store the thermal energy produced for the systems, with consequent advantages in terms of running costs.

COMBINED PRODUCTION OF HOT WATER FOR HEATING AND DOMESTIC USE

If the systems require simultaneous production of hot water for heating and for domestic use, the unit deviates the flow of water to the two separate systems via a three way valve, based on the priority assigned, changing the set point to ensure production of hot water with different temperatures based on the type of use (heating or domestic).

In this case too, storage tanks can be used to store the thermal energy for the two systems, heating and domestic hot water, ensuring continuous operation by resolving the problem of simultaneous requests for hot water production.

2. MODELS AND VERSIONS

- AWR-HT/CA-E:** high efficiency heat pump, reverse-cycle with cooling operation
- AWR-HT/LN-CA-E:** low noise high efficiency heat pump, reverse-cycle with cooling operation
- AWR-HT/D/CA-E:** high efficiency heat pump, reverse-cycle with cooling operation and partial heat recovery
- AWR-HT/D/LN-CA-E:** low noise high efficiency heat pump, reverse-cycle with cooling operation and partial heat recovery

AWR-HT: reverse-cycle heat pump with cooling operation

Reverse-cycle heat pump designed for outdoor installation producing chilled/hot water for the cooling/heating system and hot water for domestic use, with vapour-injection EVI hermetic scroll compressors operating on R407C, axial-flow fans, braze-welded plate heat exchanger and thermostatic expansion valve. Peraluman external panelling and coated galvanised steel base. The range features two compressors operating in two separate refrigerant circuits.

MODELS

Basic model

Standard reverse-cycle heat pump unit without heat recovery.

Model with partial heat recovery (D)

Reverse-cycle heat pump unit complete with partial heat recovery. In this configuration each refrigerant circuit, in addition to the basic configuration, has a refrigerant/water heat exchanger located on the gas discharge line.

This heat exchanger, placed in series downstream of the traditional condenser in the refrigerant circuit, is suitably sized to ensure heat recovery for hot water production at medium-high temperatures, for domestic or other use.

The heating capacity available is equal - as a rough approximation - to compressor power consumption.

Each heat exchanger is supplied as standard with frost protection heater.

Heat of condensation is recovered both during operation in heating mode and operation in cooling mode.

VERSIONS AVAILABLE

CA-E - Class A

High efficiency version that exceeds energy efficiency class A.

LN-CA-E - Low noise

High efficiency version in class A and low noise.

This configuration features special soundproofing for the compressor compartments and a reduction in fan speed.

Rotation speed is however automatically increased in especially demanding environmental conditions.

3. ADVANTAGES OF THE HEAT PUMP

THE EVOLUTION OF ENERGY RESOURCES

Until now, the energy used to heat rooms and domestic water in residential and service applications has accounted for a significant share of total energy consumption.

This energy is almost entirely produced using fossil fuels, meaning high levels of atmospheric pollution and with harmful effects on the environment.

Increasing environmental awareness, attention to the use of renewable sources and the drive to cut investments and operating costs, together with the need to comply with increasingly

strict legislation, are factors that play an ever more important role in determining property values but also in the development possibilities available.

Heat pumps that exploit the heat of the earth or the air now represent the best solution for heating rooms and producing domestic hot water.

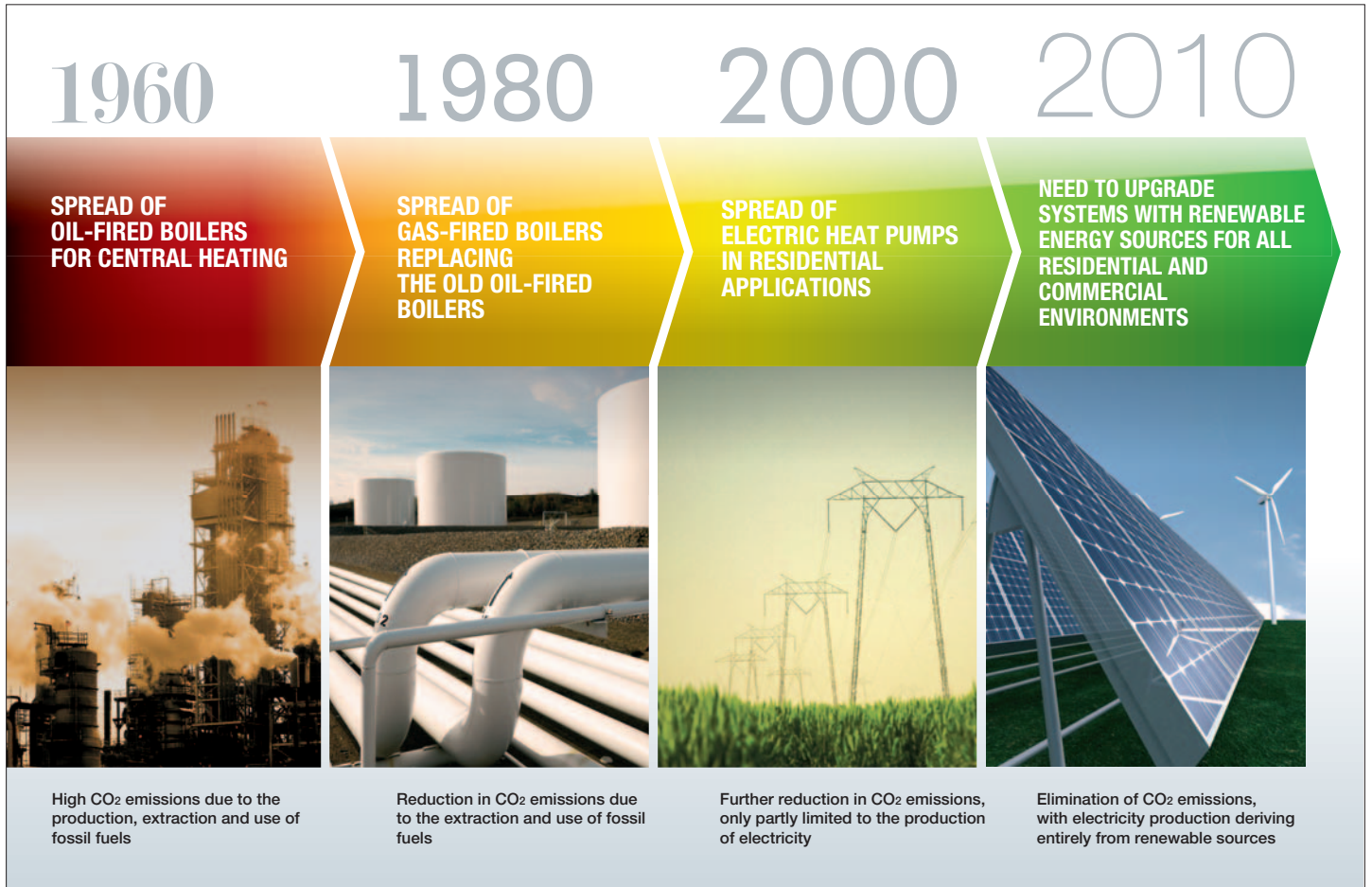

THE IMPORTANCE OF HEAT PUMPS

High temperature heat pumps are ideal for the renovation of buildings where gas- or oil-fired central heating boilers need to be replaced, however with the need to retain the existing hot water distribution system based on radiators and, at the same time, provide domestic hot water.

This situation is typical of contexts involving public buildings, such as schools and government offices, as well as in centralised residential systems such as apartment buildings, where the cost of renovation needs to be limited by keeping the same distribution system while at the same time offering a source of renewable energy, represented by the heat pump.

Renovating a building without involving the distribution system also solves the inconvenience relating to the building work that would otherwise be needed, meaning the building can still be used and consequently saving time and money.

One further advantage is represented by the possibility to use just one compact unit to manage the production of high temperature hot water for central heating and for domestic use, but also chilled water for air-conditioning in summer.

This function becomes essential in hotels where just one unit can satisfy the requirements of all the systems, ensuring the energy needs of the entire installation completely and efficiently.

For medium- and high-capacity installations, system capacity can be extended to 400 kW using a modular configuration. This type of installation allows differentiated management of domestic water production so as to optimise the use of energy resources without waste, likewise differentiating heating capacity from cooling capacity.

Its significant operating flexibility means high temperature heat pumps can be effectively used in the following applications:

- centralised systems for apartments
- public buildings
- schools
- hotels
- hospitals and clinics
- sports facilities and fitness centres

OPERATING RELIABILITY AND CONTINUITY

The new Climaveneta heat pumps offer maximum operating reliability, thanks to their two main features:

- two independent circuits for all sizes;
- system to prevent formation of ice on the coil, ensuring shorter and more efficient defrosts.

Indeed it should be remembered that a heat pump used to heat rooms has to operate at maximum capacity when the outside conditions are most adverse.

Typical night-time peaks in energy production must therefore always be ensured, regardless of the outside temperature and humidity conditions that may not allow a traditional heat pump to operate effectively.

For this reason, the Climaveneta AWR-HT units are designed and tested to ensure continuous operation and guarantee maximum indoor comfort in all weather conditions.

EXTENSION TO SERVICE AND COMMERCIAL APPLICATIONS

For medium- and high-capacity installations, system capacity can be extended to 400 kW using a modular configuration to connect up to four AWR-HT units.

In this type of installation, domestic hot water production can, if necessary, be managed by just one of the units, installing a three-way valve in the water circuit that deviates the flow of domestic hot water to a special storage tank.

This selector valve is managed directly by the AWR-HT unit, which decides when to open or close it based on the temperature conditions measured directly in the systems (heating/cooling and DHW).

The system is completely managed by the Climaveneta GR2000 sequencer, which can be used to define dynamic standby conditions and priorities for unit activation.

An alarm signal is also available via a relay output.

The LCD user interface displays the main variables relating to the system and the units.

Control can be based on proportional or proportional and integral logic. The device is integrated perfectly into the unit, ensuring simultaneous activation of devices, optimising efficiency and start-up current, and managing the pumps on the unit.

An RS485 serial line is used for connection to the other system devices.

Below is an example of an installation with 4 AWR HT units featuring domestic water production in combination with the Climaveneta GR2000 sequencer.

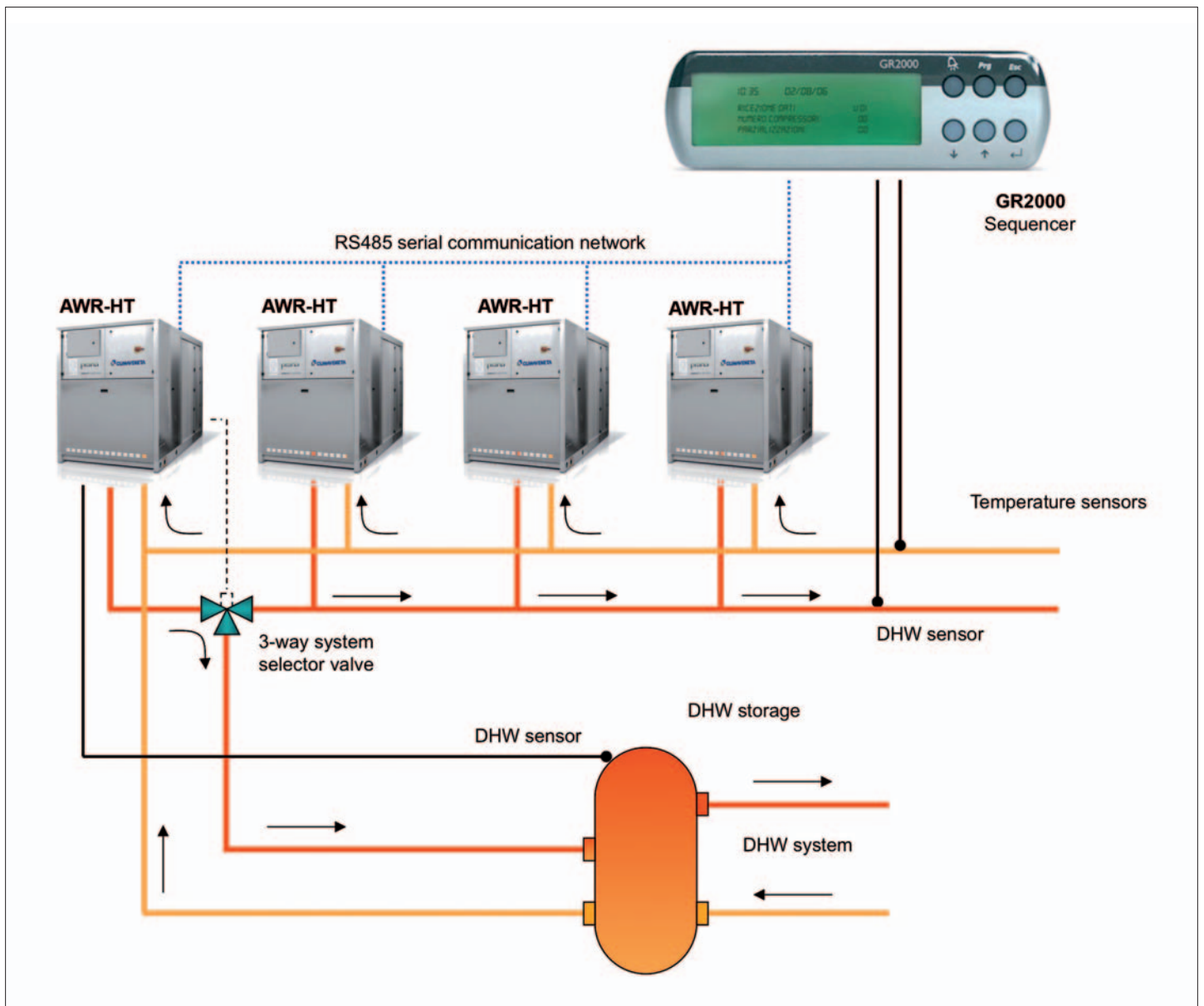

4. SPECIFICATIONS

DESCRIPTION

Reversible heat pump designed for outdoor installation producing chilled and hot high-temperature water up to 65°C for central heating and domestic use, with vapour-injection EVI hermetic scroll compressors operating on R407C, axial-flow fans, braze-welded plate heat exchanger and thermostatic expansion valve. Peraluman external panelling and coated galvanised steel base. Operating limit in summer mode: +40°C outdoor temperature. Operating limit in winter mode: -20°C outdoor temperature.

STRUCTURE

Specific structure for outdoor installation, with hot galvanized steel sheet base painted with polyester powder coat, perimeter frame made from aluminum section bars. Fan compartment separate from the compressor compartments. Specific aluminum alloy paneling for outdoor installation, completely weathertight, easily removable, designed to allow total access to internal components for inspection and maintenance (removal of front and side panels).

Condensate collection and disposal system composed by double pan, insulated with closed-cell neoprene lagging and heated by dedicated electrical heaters. Double nozzle for water expelling with a 1 1/4" diameter.

Ventilation of compressor compartments.

REFRIGERANT CIRCUIT

Main components of the refrigerant circuit:

- two separated and independent circuits with compressors operating individually in each circuit
- R407C refrigerant
- mechanical thermostatic valves
- filter dryer
- liquid flow indicator with moisture gauge
- high pressure safety valve
- low pressure safety valve
- high and low pressure transducers
- high pressure safety switches
- liquid receivers
- 4-way reversing valves
- plate heat exchanger on subcooling line
- solenoid on liquid subcooling line

COMPRESSOR

Hermetic rotary scroll compressor with vapour injection, complete with sump heater, electronic thermal protector with centralised manual reset, two-pole electric motor.

SYSTEM HEAT EXCHANGER

Braze welded AISI 316 steel plate heat exchanger. The heat exchangers are lined on the outside with closed-cell neoprene lagging. When the unit is not operating, these are protected against formation of ice on the inside by an electric heater with thermostat, while when the unit is operating protection is ensured by a differential pressure switch on the water side. The unit can also operate with non-freezing mixes, down to heat exchanger outlet temperatures of -8°C.

SOURCE HEAT EXCHANGER

Finned coil heat exchanger made from copper tubes and suitably spaced aluminium fins to guarantee maximum heat exchange efficiency, including subcooling circuit located in the bottom section of the coil.

POWER AND CONTROL ELECTRICAL PANEL

Power and control electrical panel, built in compliance with EN60204-1/IEC 204-1 standards, complete with:

- transformer for the control circuit,
 - main door interlock disconnect switch,
 - fuses and contactors for compressors and fans.
 - cumulative alarm terminals (BCA),
 - remote ON/OFF terminals,
 - spring terminal blocks for control circuits,
 - 3 way valve control terminals,
 - electrical panel for outdoor installation, with two doors and seal gaskets,
 - electronic controller
- Unit power supply voltage: 400V~ ±10% - 50 Hz - 3N.

SOURCE FAN COMPARTMENT

450 mm axial-flow fans with IP54 index of protection, external impeller, pressed metal blades, housed in aerodynamic tubes, complete with accident prevention grill. Six-pole electric motor with integrated thermal protector. Fan compartment divided into two zones to allow independent air flow for each circuit. Differentiated ventilation control with fans on inactive circuit shut down. Condenser managed by continuous control of fan rotation speed.

CERTIFICATION

Unit compliant with the following directives and amendments:

- Machinery Directive 2006/42/EC.
- EMC 89/336/EEC + 2004/108/EC.
- Low Voltage Directive 2006/95/EC.
- Pressure Equipment Directive 97/23/EC. Model A1. TÜV Italy
- Eurovent certification according to the program LCP/A/P/R

TESTS

Checks performed throughout the entire manufacturing process according to the procedures specified by ISO 9001. Performance or noise emission tests can be conducted by highly qualified technical personnel with the customer present.

Performance test involve measuring:

- electrical data
- water flow-rates
- operating temperature
- power consumption
- capacity delivered
- pressure drop on the water-source heat exchanger at both full load (in rated conditions and at the most critical conditions for the condenser) and at part load.

During performance testing the main alarm conditions can also be simulated.

Noise emission tests verify the unit's sound power levels according to ISO 3744.

5. W3000HP CONTROL ELECTRONICS

The W3000HP controller is the new device designed especially for heat pump applications with incorporated logic for high temperature hot water production.

The keypad features function controls and a complete LCD display for viewing data and activating the unit, via a multilevel menu, with settable display language.

The controller provides temperature control for the heating and cooling systems in the air-conditioned rooms, as well as for domestic hot water.

These different temperatures are managed automatically based on the different conditions in which the system operates, with the possibility to assign specific levels of priority to domestic hot water production, depending on the needs of the application.

Diagnostics include complete alarm management, with “black box” functions (via PC) and alarm log (display or PC) for best analysis of unit behaviour.

For systems made up of multiple units, differentiated device management means just a certain portion of the capacity installed can be dedicated to domestic water production, in this way ensuring more efficient energy distribution and, at the same time, guaranteeing simultaneous water delivery to the different distribution systems.

The built-in clock can be used to create an operating profile containing up to 4 typical days and 10 time bands, essential for efficient programming of energy production, and fundamental for managing the Legionella prevention cycles.

Defrosts use proprietary self-adaptive logic involving monitoring of multiple operating and climate parameters.

This reduces the number and duration of defrosts, consequently increasing overall energy efficiency.

Supervision is available with different options, using proprietary devices or by integration into third party systems using ModBus, BACnet, BACnet-over-IP and Echelon LonWorks protocols.

A dedicated wall-mounted keypad can be used for remote control of all the functions.



6. ACCESSORIES

ACCESSORIES	DESCRIPTION	BENEFIT
Cu/Cu condensing coils	Air-refrigerant heat exchanger with copper fins and tubes.	Recommended for applications in corrosive atmospheres
Condensing coils with epoxy-coated fins	Painted air-refrigerant heat exchanger.	Recommended for applications in medium level pollution atmospheres.
Condensing coils with Fin Guard Silver treatment	Air-refrigerant heat exchanger with epoxidic treatment on coils and fins.	Recommended for marine exposure conditions, with an high level of pollution or other aggressive atmospheres.
Soft start	Electronic device adopted to manage the inrush current.	Break down of the inrush current as soon as the electrical motor is switch on, lower motor's mechanical wear, favourable sizing for the electrical system.
Remote phase-sequence control	Relay for controlling the phase-sequence of mains.	Protects loads against faults due to incorrect connection of the electric line.
Compressors' on/off signal	Auxiliary contacts providing a voltage-free signal	Allows remote signalling of compressor's activation or remote control of any auxiliary loads.
ModBUS connectivity	Interface module for ModBUS protocols	Allows integration with BMS operating with ModBUS protocol
BACnet connectivity	Interface module for BACnet protocols	Allows integration with BMS operating with BACnet protocol
Echelon connectivity	Interface module for Echelon systems	Allows integration with BMS operating with Lon-Works protocols
HP and LP gauges	High and low pressure gauges.	Allows immediate reading of the pressure values on both low and high pressure circuits.
Compressor suction valve	Shut-off solenoid valve on compressor's suction circuit.	Simplifies maintenance activities
Compr. discharge line valve	Shut-off solenoid valve on compressor discharge circuit	Simplifies maintenance activities.
Cond. coil protection net	Coil protecting net	Protects against the intrusion of solid bodies with medium/large dimensions.
Extra insulation for the compressors section	Acoustic enclosure on both compressor and pump sections (when applicable)	Noise emission reduction
BACnet OVER-IP connectivity	Interface module for BACnet OVER-IP protocols (LN standard version)	Allows to interconnect BACnet devices over Internet Protocol within wide-area networks
Pressure relief valves	Dual relief valve with manual diverting switch	Allows to unselect a relief valve in order to service the unit avoiding medium or long inoperative periods
Arrangement for 3 way on field	Arrangement for a 3 way valve for remote installation for the production of domestic hot water	Allows to divert the water flow through the space heating system and the domestic hot water circuit according to the assigned priority level. The control of the flow is based on the water temperature detected by a dedicated sensor placed on the DHW boiler. The unit comes standard without the built in valve. The valve must be installed externally and can placed close to the DHW boiler, thus simplifying the water circuit.
With 3 way valve on board	3 way valve built-in installed for the production of domestic hot water	Allows to divert the water flow through the space heating system and the domestic hot water circuit according to the assigned priority level. The control of flow is based on the water temperature detected by a dedicated sensor placed on the DHW boiler. The unit comes with the valve factory built in. The actuator is installed into a dedicated board with an electrical heater, protected against low ambient temperature. The built in valve allows to simplify the on-site installation operations.

APPLICATION HYDRONIC TERMINAL

AWR-HT / CA-E		0122	0152	0202	0262	0302	
Power supply		V/ph/Hz 400/3/50+N 400/3/50+N 400/3/50+N 400/3/50+N 400/3/50+N					
PERFORMANCE							
COOLING ONLY (GROSS VALUE)							
Cooling capacity	(1)	kW	34,1	43,8	60,3	76,4	91,7
Total power input	(1)	kW	11,6	14,7	20,4	25,8	31,3
EER	(1)		2,94	2,98	2,96	2,96	2,93
ESEER	(1)		3,40	3,34	3,40	3,38	3,35
COOLING ONLY (EN14511 VALUE)							
Cooling capacity	(1)(2)	kW	34,0	43,7	60,2	76,2	91,4
EER	(1)(2)		2,91	2,95	2,93	2,93	2,90
ESEER	(1)(2)		3,34	3,26	3,33	3,30	3,27
Cooling energy class			B	B	B	B	B
HEATING ONLY (GROSS VALUE)							
Heating capacity	(3)	kW	38,0	51,3	68,8	84,9	102
Total power input	(3)	kW	10,7	14,4	19,4	23,6	27,7
COP	(3)		3,55	3,56	3,55	3,60	3,68
HEATING ONLY (EN14511 VALUE)							
Heating capacity	(3)(2)	kW	38,1	51,4	69,0	85,2	102
COP	(3)(2)		3,53	3,54	3,52	3,57	3,65
Cooling energy class			A	A	A	A	A
COOLING WITH PARTIAL RECOVERY							
Cooling capacity	(4)	kW	35,4	45,4	62,6	79,3	95,1
Total power input	(4)	kW	11,2	14,2	19,8	25,0	30,3
Desuperheater heating capacity	(4)	kW	9,46	11,8	16,4	21,2	26,2
EXCHANGERS							
HEAT EXCHANGER USER SIDE IN REFRIGERATION							
Water flow	(1)	m³/h	5,87	7,54	10,4	13,2	15,8
Pressure drop	(1)	kPa	8,10	9,21	11,0	14,5	18,2
HEAT EXCHANGER USER SIDE IN HEATING							
Water flow	(3)	m³/h	6,60	8,91	12,0	14,8	17,7
Pressure drop	(3)	kPa	10,2	12,9	14,6	18,3	22,9
PARTIAL RECOVERY USER SIDE IN							
Water flow	(4)	m³/h	1,64	2,05	2,85	3,69	4,54
Pressure drop	(4)	kPa	2,77	4,29	3,60	6,02	9,13
COMPRESSORS							
N. of compressors		N°	2	2	2	2	2
Number of capacity		N°	2	2	2	2	2
No. of circuits		N°	2	2	2	2	2
Regulation		STEPS	STEPS	STEPS	STEPS	STEPS	
Min. capacity step		%	50	50	50	50	50
Refrigerant			R407C	R407C	R407C	R407C	R407C
Refrigerant charge		kg	18,0	26,0	30,0	33,0	40,0
Oil charge		kg	3,80	8,00	8,00	8,20	8,20
FANS							
Quantity		N°	2	3	4	4	4
Air flow		m³/s	5,15	7,51	10,4	10,6	10,4
Fans power		kW	0,25	0,25	0,25	0,25	0,25
NOISE LEVEL							
Noise Pressure	(5)	dB(A)	68	69	70	70	70
Noise Power	(6)	dB(A)	84	86	87	87	87
SIZE AND WEIGHT							
A	(7)	mm	1695	2195	2745	2745	2745
B	(7)	mm	1120	1120	1120	1120	1120
H	(7)	mm	1420	1420	1420	1620	1620
Operating weight	(7)	kg	510	750	870	940	1030

Notes:

- 1 Plant (side) cooling exchanger water (in/out) 12°C/7°C; Source (side) heat exchanger air (in) 35°C
 - 2 Values in compliance with EN14511-3:2011
 - 3 Plant (side) heat exchanger water (in/out) 40°C/45°C; Source (side) heat exchanger air (in) 7°C - 87% R.H.
 - 4 Plant (side) cooling exchanger water (in/out) 12°C/7°C; Source (side) heat exchanger air (in) 35°C; Plant (side) heat exchanger recovery water (in/out) 40°C/45°C
 - 5 Average sound pressure level, at 1m distance, unit in a free field on a reflective surface; non-binding value obtained from the sound power level.
 - 6 Sound power on the basis of measurements made in compliance with ISO 9614 and Eurovent 8/1 for Eurovent certified units; in compliance with ISO 3744 for non-certified units.
 - 7 Unit in standard configuration/execution, without optional accessories.
- Unavailable

APPLICATION HYDRONIC TERMINAL

AWR-HT / LN-CA-E		0122	0152	0202	0262	0302	
Power supply		V/ph/Hz 400/3/50+N 400/3/50+N 400/3/50+N 400/3/50+N 400/3/50+N					
PERFORMANCE							
COOLING ONLY (GROSS VALUE)							
Cooling capacity	(1)	kW	34,0	43,9	60,2	76,2	90,4
Total power input	(1)	kW	11,6	14,9	20,5	26,1	32,9
EER	(1)		2,93	2,95	2,94	2,92	2,75
ESEER	(1)		3,38	3,31	3,36	3,34	3,18
COOLING ONLY (EN14511 VALUE)							
Cooling capacity	(1)(2)	kW	33,9	43,8	60,1	76,0	90,1
EER	(1)(2)		2,90	2,92	2,91	2,89	2,72
ESEER	(1)(2)		3,33	3,22	3,29	3,28	3,10
Cooling energy class			B	B	B	C	C
HEATING ONLY (GROSS VALUE)							
Heating capacity	(3)	kW	38,4	51,0	69,4	85,8	100
Total power input	(3)	kW	10,7	14,3	19,4	23,7	27,6
COP	(3)		3,59	3,57	3,58	3,62	3,63
HEATING ONLY (EN14511 VALUE)							
Heating capacity	(3)(2)	kW	38,5	51,1	69,6	86,1	101
COP	(3)(2)		3,56	3,54	3,55	3,59	3,60
Cooling energy class			A	A	A	A	A
COOLING WITH PARTIAL RECOVERY							
Cooling capacity	(4)	kW	35,3	45,5	62,5	79,1	93,8
Total power input	(4)	kW	11,2	14,4	19,9	25,3	31,8
Desuperheater heating capacity	(4)	kW	9,46	12,0	16,5	21,5	27,6
EXCHANGERS							
HEAT EXCHANGER USER SIDE IN REFRIGERATION							
Water flow	(1)	m³/h	5,85	7,56	10,4	13,1	15,6
Pressure drop	(1)	kPa	8,05	9,25	11,0	14,5	17,7
HEAT EXCHANGER USER SIDE IN HEATING							
Water flow	(3)	m³/h	6,67	8,86	12,1	14,9	17,4
Pressure drop	(3)	kPa	10,5	12,7	14,8	18,7	22,2
PARTIAL RECOVERY USER SIDE IN							
Water flow	(4)	m³/h	1,64	2,08	2,87	3,74	4,79
Pressure drop	(4)	kPa	2,77	4,42	3,64	6,18	10,2
COMPRESSORS							
N. of compressors		N°	2	2	2	2	2
Number of capacity		N°	2	2	2	2	2
No. of circuits		N°	2	2	2	2	2
Regulation		STEPS	STEPS	STEPS	STEPS	STEPS	
Min. capacity step		%	50	50	50	50	50
Refrigerant			R407C	R407C	R407C	R407C	R407C
Refrigerant charge		kg	19,0	27,0	32,0	35,0	42,0
Oil charge		kg	3,80	8,00	8,00	8,20	8,20
FANS							
Quantity		N°	2	3	4	4	4
Air flow		m³/s	4,17	6,25	8,42	8,68	8,68
Fans power		kW	0,25	0,25	0,25	0,25	0,25
NOISE LEVEL							
Noise Pressure	(5)	dB(A)	64	65	66	66	67
Noise Power	(6)	dB(A)	80	82	83	83	84
SIZE AND WEIGHT							
A	(7)	mm	1695	2195	2745	2745	2745
B	(7)	mm	1120	1120	1120	1120	1120
H	(7)	mm	1420	1420	1420	1620	1620
Operating weight	(7)	kg	550	780	940	1010	1060

Notes:

- 1 Plant (side) cooling exchanger water (in/out) 12°C/7°C; Source (side) heat exchanger air (in) 35°C
 - 2 Values in compliance with EN14511-3:2011
 - 3 Plant (side) heat exchanger water (in/out) 40°C/45°C; Source (side) heat exchanger air (in) 7°C - 87% R.H.
 - 4 Plant (side) cooling exchanger water (in/out) 12°C/7°C; Source (side) heat exchanger air (in) 35°C; Plant (side) heat exchanger recovery water (in/out) 40°C/45°C
 - 5 Average sound pressure level, at 1m distance, unit in a free field on a reflective surface; non-binding value obtained from the sound power level.
 - 6 Sound power on the basis of measurements made in compliance with ISO 9614 and Eurovent 8/1 for Eurovent certified units; in compliance with ISO 3744 for non-certified units.
 - 7 Unit in standard configuration/execution, without optional accessories.
- Unavailable

7. GENERAL TECHNICAL DATA

AWR-HT / CA-E

SIZE		0122	0152	0202	0262	0302		
AWR-HT /CA-E								
COOLING ⁽¹⁾								
Cooling capacity	kW	43,7	56,3	77,2	98,0	118		
Total power input (unit)	kW	12,4	15,5	21,9	28,6	35,0		
EER		3,52	3,63	3,53	3,43	3,38		
ESEER		3,4	3,34	3,4	3,38	3,35		
Heat exchanger water flow	m ³ /h	7,54	9,72	13,3	16,9	20,4		
Heat exchanger pressure drop	kPa	13,4	15,3	18,1	24,0	30,5		
AWR-HT /CA-E								
HEATING ⁽²⁾								
Heating capacity	kW	38,0	51,3	68,8	84,9	102		
Total power input (unit)	kW	10,7	14,4	19,4	23,6	27,7		
COP		3,55	3,56	3,55	3,60	3,68		
Heat exchanger water flow	m ³ /h	6,60	8,91	12,0	14,8	17,7		
Heat exchanger pressure drop	kPa	10,2	12,9	14,6	18,3	22,9		
AWR-HT /D /CA-E								
COOLING WITH PARTIAL RECOVERY ⁽³⁾								
Cooling capacity	kW	45,3	58,4	80,1	102	123		
Total power input (unit)	kW	12,0	15,0	21,2	27,7	33,8		
Heat exchanger water flow	m ³ /h	7,54	9,72	13,3	16,9	20,4		
Heat exchanger pressure drop	kPa	13,4	15,3	18,1	24,0	30,5		
Heat recovery thermal capacity	kW	10,2	12,5	17,8	23,7	29,5		
Heat exchanger recovery water flow	m ³ /h	1,77	2,17	3,09	4,13	5,12		
Plant side heat exchanger recovery pressure drop	kPa	3,20	4,83	4,21	7,52	11,6		
COMPRESSORS								
Number	N°.	2	2	2	2	2		
Number of capacity	N°.	2	2	2	2	2		
Number of circuits	N°.	2	2	2	2	2		
Type of regulation	STEPS	STEPS	STEPS	STEPS	STEPS	STEPS		
Minimum capacity steps	%	50	50	50	50	50		
Type of refrigerant	R407C	R407C	R407C	R407C	R407C	R407C		
Refrigerant charge	kg.	18	26	30	33	40		
Oil charge	kg.	3,8	8	8	8,2	8,2		
FANS								
Number	N°.	4	6	8	8	8		
Air flow	m ³ /s	5,15	7,51	10,4	10,6	10,4		
Single power input	kW	0,25	0,25	0,25	0,25	0,25		
NOISE LEVELS ⁽⁴⁾								
Total sound power	dB(A)	84	86	87	87	87		
Total sound pressure	dB(A)	52	54	55	55	55		
DIMENSIONS AND WEIGHTS ⁽⁵⁾								
Length	mm.	1695	2195	2745	2745	2745		
Width	mm.	1120	1120	1120	1120	1120		
Height	mm.	1420	1420	1420	1620	1620		
Weight	kg.	510	750	870	940	1030		

1 Plant (side) cooling exchanger water (in/out) 23/18 °C

Heat exchanger air (in) 35 °C

2 Plant (side) heating exchanger water (in/out) 40/45 °C

Source (side) heat exchanger air (in) 7 °C 87% R.H.

3 Plant (side) cooling exchanger water (in/out) 23/18 °C

Heat exchanger air (in) 35 °C

Plant (side) heat exchanger recovery water (in/out) 40/45 °C

4 Sound power on the basis of measurements made in compliance with ISO 9614 and Eurovent 8/1 for Eurovent certified units; in compliance with ISO 3744 for non-certified units

Average sound pressure level, at 10 (m.) distance, unit in a free field on a reflective surface; non-binding value obtained from the sound power level

5 Standard configuration

- Not available

7. GENERAL TECHNICAL DATA

AWR-HT / LN-CA-E

SIZE		0122	0152	0202	0262	0302		
AWR-HT /LN-CA-E								
COOLING ⁽¹⁾								
Cooling capacity	kW	43,6	56,2	77,0	97,6	116		
Total power input (unit)	kW	12,5	15,9	22,0	29,0	37,2		
EER		3,49	3,53	3,50	3,37	3,13		
ESEER		3,38	3,31	3,36	3,34	3,18		
Heat exchanger water flow	m ³ /h	7,53	9,70	13,3	16,8	20,1		
Heat exchanger pressure drop	kPa	13,3	15,2	18,0	23,8	29,5		
AWR-HT /LN-CA-E								
HEATING ⁽²⁾								
Heating capacity	kW	38,4	51,0	69,4	85,8	100		
Total power input (unit)	kW	10,7	14,3	19,4	23,7	27,6		
COP		3,59	3,57	3,58	3,62	3,63		
Heat exchanger water flow	m ³ /h	6,67	8,86	12,1	14,9	17,4		
Heat exchanger pressure drop	kPa	10,5	12,7	14,8	18,7	22,2		
AWR-HT /D /LN-CA-E								
COOLING WITH PARTIAL RECOVERY ⁽³⁾								
Cooling capacity	kW	45,2	58,3	79,9	101	121		
Total power input (unit)	kW	12,1	15,4	21,3	28,1	36,0		
Heat exchanger water flow	m ³ /h	7,53	9,70	13,3	16,8	20,1		
Heat exchanger pressure drop	kPa	13,3	15,2	18,0	23,8	29,5		
Heat recovery thermal capacity	kW	10,3	12,9	17,9	24,1	31,4		
Heat exchanger recovery water flow	m ³ /h	1,78	2,23	3,10	4,19	5,46		
Plant side heat exchanger recovery pressure drop	kPa	3,26	5,11	4,25	7,75	13,2		
COMPRESSORS								
Number	N°.	2	2	2	2	2		
Number of capacity	N°.	2	2	2	2	2		
Number of circuits	N°.	2	2	2	2	2		
Type of regulation		STEPS	STEPS	STEPS	STEPS	STEPS		
Minimum capacity steps	%	50	50	50	50	50		
Type of refrigerant		R407C	R407C	R407C	R407C	R407C		
Refrigerant charge	kg.	18	26	30	33	40		
Oil charge	kg.	3,8	8	8	8,2	8,2		
FANS								
Number	N°.	4	6	8	8	8		
Air flow	m ³ /s	4,17	6,25	8,42	8,68	8,68		
Single power input	kW	0,25	0,25	0,25	0,25	0,25		
NOISE LEVELS ⁽⁴⁾								
Total sound power	dB(A)	80	82	83	83	84		
Total sound pressure	dB(A)	48	50	51	51	52		
DIMENSIONS AND WEIGHTS ⁽⁵⁾								
Length	mm.	1695	2195	2745	2745	2745		
Width	mm.	1120	1120	1120	1120	1120		
Height	mm.	1420	1420	1420	1620	1620		
Weight	kg.	530	760	910	980	1030		

1 Plant (side) cooling exchanger water (in/out) 23/18 °C

Heat exchanger air (in) 35 °C

2 Plant (side) heating exchanger water (in/out) 40/45 °C

Source (side) heat exchanger air (in) 7 °C 87% R.H.

3 Plant (side) cooling exchanger water (in/out) 23/18 °C

Heat exchanger air (in) 35 °C

Plant (side) heat exchanger recovery water (in/out) 40/45 °C

4 Sound power on the basis of measurements made in compliance with ISO 9614 and Eurovent 8/1 for Eurovent certified units; in compliance with ISO 3744 for non-certified units

Average sound pressure level, at 10 (m.) distance, unit in a free field on a reflective surface; non-binding value obtained from the sound power level

5 Standard configuration

- Not available

8. COOLING CAPACITY PERFORMANCE

AWR-HT / CA-E

0122																		
Ta	25	30	32	35	40	46	25	30	32	35	40	46	25	30	32	35	40	46
Tev	6						7						8					
Pf	34,9	34,0	33,7	33,1	32,3	31,2	35,9	35,0	34,6	34,1	33,2	32,1	36,9	36,0	35,6	35,0	34,1	33,0
Pat	9,43	10,4	10,8	11,5	12,8	14,5	9,50	10,5	10,9	11,6	12,9	14,7	9,57	10,5	11,0	11,7	13,0	14,8
Qev	6,01	5,86	5,80	5,70	5,55	5,37	6,18	6,03	5,96	5,87	5,72	5,53	6,35	6,19	6,13	6,03	5,88	5,69
Dpev	8,49	8,06	7,89	7,65	7,24	6,77	8,98	8,53	8,36	8,10	7,68	7,19	9,47	9,01	8,83	8,56	8,12	7,60
Tev	9						10						11					
Pf	37,8	36,9	36,5	36,0	35,0	33,9	38,8	37,8	37,4	36,9	35,9	34,8	39,7	38,7	38,4	37,8	36,8	35,7
Pat	9,64	10,6	11,1	11,8	13,1	14,9	9,70	10,7	11,2	11,9	13,2	15,1	9,76	10,8	11,2	12,0	13,3	15,2
Qev	6,52	6,36	6,29	6,20	6,04	5,85	6,68	6,52	6,45	6,35	6,19	6,00	6,84	6,68	6,61	6,51	6,35	6,15
Dpev	9,98	9,49	9,30	9,02	8,56	8,03	10,5	9,98	9,78	9,49	9,01	8,46	11,0	10,5	10,3	9,96	9,47	8,90
0152																		
Ta	25	30	32	35	40	46	25	30	32	35	40	46	25	30	32	35	40	46
Tev	6						7						8					
Pf	44,4	43,6	43,2	42,6	41,4	39,8	45,7	44,8	44,4	43,8	42,6	40,9	47,0	46,1	45,7	45,0	43,8	42,1
Pat	12,3	13,4	13,9	14,6	15,9	17,5	12,4	13,5	14,0	14,7	16,0	17,7	12,5	13,6	14,1	14,8	16,1	17,8
Qev	7,64	7,50	7,43	7,32	7,13	6,85	7,87	7,72	7,65	7,54	7,33	7,05	8,09	7,94	7,87	7,75	7,54	7,24
Dpev	9,46	9,10	8,95	8,69	8,22	7,60	10,0	9,65	9,48	9,21	8,71	8,05	10,6	10,2	10,0	9,74	9,21	8,50
Tev	9						10						11					
Pf	48,3	47,3	46,9	46,2	44,9	43,2	49,5	48,6	48,1	47,4	46,1	44,2	50,8	49,8	49,3	48,6	47,2	45,3
Pat	12,6	13,7	14,2	14,9	16,2	18,0	12,6	13,8	14,2	15,0	16,4	18,1	12,7	13,8	14,3	15,1	16,5	18,3
Qev	8,31	8,15	8,08	7,96	7,74	7,43	8,53	8,37	8,29	8,17	7,94	7,62	8,75	8,58	8,50	8,37	8,14	7,81
Dpev	11,2	10,8	10,6	10,3	9,71	8,95	11,8	11,3	11,1	10,8	10,2	9,41	12,4	11,9	11,7	11,4	10,7	9,87
0202																		
Ta	25	30	32	35	40	46	25	30	32	35	40	46	25	30	32	35	40	46
Tev	6						7						8					
Pf	61,6	60,1	59,5	58,6	57,2	55,5	63,4	61,8	61,2	60,3	58,8	57,0	65,1	63,5	62,9	62,0	60,4	58,6
Pat	16,8	18,4	19,1	20,2	22,2	24,8	16,9	18,6	19,3	20,4	22,4	25,0	17,0	18,7	19,4	20,6	22,6	25,3
Qev	10,6	10,3	10,2	10,1	9,84	9,55	10,9	10,6	10,5	10,4	10,1	9,82	11,2	10,9	10,8	10,7	10,4	10,1
Dpev	11,5	10,9	10,7	10,4	9,88	9,30	12,2	11,6	11,3	11,0	10,5	9,84	12,8	12,2	12,0	11,6	11,0	10,4
Tev	9						10						11					
Pf	66,9	65,2	64,6	63,6	62,0	60,1	68,6	66,9	66,2	65,2	63,6	61,6	70,2	68,5	67,8	66,8	65,1	63,1
Pat	17,1	18,9	19,6	20,7	22,8	25,5	17,3	19,0	19,7	20,9	23,0	25,8	17,4	19,1	19,9	21,1	23,2	26,0
Qev	11,5	11,2	11,1	11,0	10,7	10,4	11,8	11,5	11,4	11,2	10,9	10,6	12,1	11,8	11,7	11,5	11,2	10,9
Dpev	13,5	12,9	12,6	12,2	11,6	10,9	14,2	13,5	13,3	12,9	12,2	11,5	14,9	14,2	13,9	13,5	12,8	12,1
0262																		
Ta	25	30	32	35	40	46	25	30	32	35	40	46	25	30	32	35	40	46
Tev	6						7						8					
Pf	78,3	76,3	75,5	74,3	72,0	69,2	80,6	78,6	77,7	76,4	74,1	71,2	82,9	80,8	79,9	78,5	76,1	73,1
Pat	21,4	23,3	24,1	25,5	28,0	31,3	21,6	23,6	24,4	25,8	28,3	31,7	21,8	23,8	24,7	26,1	28,6	32,0
Qev	13,5	13,1	13,0	12,8	12,4	11,9	13,9	13,5	13,4	13,2	12,8	12,3	14,3	13,9	13,8	13,5	13,1	12,6
Dpev	15,3	14,5	14,2	13,7	12,9	11,9	16,2	15,4	15,0	14,5	13,7	12,6	17,1	16,2	15,9	15,4	14,4	13,3
Tev	9						10						11					
Pf	85,1	82,9	82,0	80,6	78,1	75,0	87,3	85,0	84,1	82,7	80,1	76,9	89,4	87,1	86,2	84,7	82,1	78,8
Pat	22,1	24,1	25,0	26,4	29,0	32,4	22,3	24,3	25,2	26,7	29,3	32,7	22,5	24,6	25,5	26,9	29,6	33,1
Qev	14,7	14,3	14,1	13,9	13,5	12,9	15,0	14,6	14,5	14,2	13,8	13,2	15,4	15,0	14,8	14,6	14,1	13,6
Dpev	18,0	17,1	16,8	16,2	15,2	14,0	19,0	18,0	17,6	17,0	16,0	14,7	20,0	18,9	18,5	17,9	16,8	15,5
0302																		
Ta	25	30	32	35	40	46	25	30	32	35	40	46	25	30	32	35	40	46
Tev	6						7						8					
Pf	93,9	91,6	90,6	89,1	86,5	83,1	96,7	94,3	93,3	91,7	89,0	85,6	99,4	96,9	95,9	94,3	91,5	88,0
Pat	25,7	28,1	29,2	30,9	34,2	38,6	26,0	28,4	29,5	31,3	34,6	39,1	26,3	28,8	29,9	31,7	35,0	39,6
Qev	16,2	15,8	15,6	15,3	14,9	14,3	16,6	16,2	16,1	15,8	15,3	14,7	17,1	16,7	16,5	16,2	15,8	15,2
Dpev	19,1	18,1	17,7	17,2	16,2	14,9	20,2	19,2	18,8	18,2	17,1	15,8	21,4	20,3	19,9	19,2	18,1	16,8
Tev	9						10						11					
Pf	102	99,5	98,5	96,8	94,0	90,4	105	102	101	99,4	96,5	92,8	107	105	104	102	98,9	95,1
Pat	26,7	29,1	30,2	32,1	35,5	40,1	27,0	29,5	30,6	32,4	35,9	40,6	27,3	29,8	30,9	32,8	36,3	41,1
Qev	17,6	17,1	17,0	16,7	16,2	15,6	18,0	17,6	17,4	17,1	16,6	16,0	18,5	18,0	17,8	17,6	17,0	16,4
Dpev	22,6	21,5	21,0	20,3	19,1	17,7	23,8	22,6	22,1	21,4	20,2	18,7	25,0	23,8	23,3	22,5	21,2	19,6

Ta [°C] - Air temperature

Tev [°C] - Plant (side) cooling exchanger output water temperature

Pat [kW] - Total power input

Qev [m³/h] - Plant (side) heat exchanger water flow

Dpev [kPa] - Plant (side) cooling exchanger pressure drop

Pf [kW] - Cooling capacity

'-' Conditions outside the operating range

Waterflow and pressure drop on heat exchangers calculated with 5°C of delta T

NOTE: Data on grey background: unit switched to non-silenced operation

8. COOLING CAPACITY PERFORMANCE

AWR-HT / LN-CA-E

0122																		
Ta	25	30	32	35	40	46	25	30	32	35	40	46	25	30	32	35	40	46
Tev	6						7						8					
Pf	34,8	33,9	33,5	33,0	32,3	31,4	35,8	34,9	34,5	34,0	33,2	32,3	36,8	35,8	35,5	34,9	34,1	33,2
Pat	9,42	10,3	10,8	11,5	12,9	14,8	9,50	10,4	10,9	11,6	13,0	15,0	9,58	10,5	11,0	11,7	13,1	15,1
Qev	5,99	5,83	5,77	5,69	5,55	5,41	6,16	6,00	5,94	5,85	5,72	5,57	6,33	6,17	6,11	6,02	5,88	5,72
Dpev	8,44	8,00	7,84	7,60	7,25	6,87	8,93	8,47	8,30	8,05	7,68	7,28	9,42	8,94	8,76	8,51	8,11	7,69
Tev	9						10						11					
Pf	37,7	36,8	36,4	35,9	35,0	34,1	38,7	37,7	37,3	36,8	35,9	35,0	39,6	38,6	38,2	37,7	36,8	35,9
Pat	9,65	10,6	11,1	11,8	13,2	15,3	9,72	10,7	11,1	11,9	13,3	15,4	9,79	10,8	11,2	12,0	13,4	15,5
Qev	6,50	6,33	6,27	6,18	6,03	5,88	6,66	6,49	6,43	6,34	6,19	6,03	6,82	6,65	6,59	6,49	6,34	6,18
Dpev	9,92	9,42	9,23	8,97	8,56	8,12	10,4	9,91	9,71	9,43	9,00	8,54	10,9	10,4	10,2	9,90	9,45	8,97
0152																		
Ta	25	30	32	35	40	46	25	30	32	35	40	46	25	30	32	35	40	46
Tev	6						7						8					
Pf	44,6	43,7	43,3	42,7	41,4	39,6	45,9	45,0	44,6	43,9	42,6	40,8	47,2	46,3	45,8	45,1	43,8	41,9
Pat	12,5	13,6	14,0	14,8	16,2	18,0	12,6	13,7	14,1	14,9	16,3	18,2	12,7	13,8	14,3	15,0	16,4	18,4
Qev	7,67	7,53	7,46	7,34	7,13	6,82	7,90	7,75	7,68	7,56	7,33	7,02	8,13	7,96	7,89	7,77	7,54	7,22
Dpev	9,54	9,18	9,01	8,74	8,23	7,54	10,1	9,72	9,54	9,25	8,71	7,98	10,7	10,3	10,1	9,78	9,21	8,43
Tev	9						10						11					
Pf	48,5	47,5	47,0	46,3	44,9	43,0	49,7	48,7	48,2	47,5	46,1	44,1	51,0	49,9	49,4	48,6	47,2	45,2
Pat	12,8	13,9	14,4	15,1	16,6	18,5	12,9	14,0	14,5	15,2	16,7	18,6	12,9	14,1	14,6	15,3	16,8	18,8
Qev	8,35	8,18	8,10	7,98	7,74	7,41	8,57	8,39	8,31	8,18	7,94	7,60	8,78	8,60	8,52	8,38	8,13	7,79
Dpev	11,3	10,8	10,6	10,3	9,70	8,89	11,9	11,4	11,2	10,8	10,2	9,35	12,5	12,0	11,8	11,4	10,7	9,82
0202																		
Ta	25	30	32	35	40	46	25	30	32	35	40	46	25	30	32	35	40	46
Tev	6						7						8					
Pf	61,5	60,0	59,4	58,5	57,1	55,4	63,3	61,7	61,1	60,2	58,7	56,9	65,0	63,4	62,8	61,8	60,3	58,5
Pat	16,9	18,5	19,2	20,3	22,3	24,8	17,0	18,7	19,4	20,5	22,5	25,1	17,1	18,8	19,5	20,7	22,7	25,4
Qev	10,6	10,3	10,2	10,1	9,82	9,53	10,9	10,6	10,5	10,4	10,1	9,80	11,2	10,9	10,8	10,6	10,4	10,1
Dpev	11,4	10,9	10,7	10,4	9,84	9,26	12,1	11,5	11,3	11,0	10,4	9,80	12,8	12,2	11,9	11,6	11,0	10,3
Tev	9						10						11					
Pf	66,7	65,1	64,4	63,5	61,9	60,0	68,4	66,7	66,1	65,1	63,4	61,5	70,1	68,4	67,7	66,6	65,0	63,0
Pat	17,2	19,0	19,7	20,9	22,9	25,6	17,4	19,1	19,8	21,0	23,1	25,9	17,5	19,2	20,0	21,2	23,3	26,1
Qev	11,5	11,2	11,1	10,9	10,7	10,3	11,8	11,5	11,4	11,2	10,9	10,6	12,1	11,8	11,7	11,5	11,2	10,9
Dpev	13,5	12,8	12,6	12,2	11,6	10,9	14,2	13,5	13,2	12,8	12,2	11,5	14,9	14,1	13,9	13,5	12,8	12,0
0262																		
Ta	25	30	32	35	40	46	25	30	32	35	40	46	25	30	32	35	40	46
Tev	6						7						8					
Pf	78,1	76,2	75,3	74,1	71,8	69,0	80,4	78,4	77,5	76,2	73,9	71,0	82,6	80,5	79,7	78,3	75,9	72,9
Pat	21,5	23,5	24,4	25,8	28,3	31,5	21,7	23,8	24,7	26,1	28,6	31,9	21,9	24,1	25,0	26,4	28,9	32,2
Qev	13,4	13,1	13,0	12,7	12,4	11,9	13,8	13,5	13,3	13,1	12,7	12,2	14,2	13,9	13,7	13,5	13,1	12,6
Dpev	15,2	14,4	14,1	13,7	12,8	11,9	16,1	15,3	15,0	14,5	13,6	12,5	17,0	16,2	15,8	15,3	14,4	13,2
Tev	9						10						11					
Pf	84,9	82,7	81,8	80,4	77,9	74,8	87,0	84,8	83,9	82,4	79,9	76,7	89,2	86,9	85,9	84,4	81,8	78,5
Pat	22,2	24,3	25,3	26,7	29,3	32,6	22,4	24,6	25,5	27,0	29,6	33,0	22,6	24,8	25,8	27,3	29,9	33,3
Qev	14,6	14,2	14,1	13,8	13,4	12,9	15,0	14,6	14,4	14,2	13,8	13,2	15,4	15,0	14,8	14,5	14,1	13,5
Dpev	17,9	17,0	16,7	16,1	15,1	13,9	18,9	17,9	17,5	16,9	15,9	14,7	19,8	18,8	18,4	17,8	16,7	15,4
0302																		
Ta	25	30	32	35	40	46	25	30	32	35	40	46	25	30	32	35	40	46
Tev	6						7						8					
Pf	92,9	90,4	89,4	87,8	85,1	81,7	95,6	93,1	92,0	90,4	87,6	84,1	98,3	95,7	94,6	92,9	90,1	86,4
Pat	26,7	29,4	30,6	32,4	35,9	40,5	27,1	29,8	31,0	32,9	36,4	41,1	27,5	30,2	31,4	33,3	36,9	41,7
Qev	16,0	15,6	15,4	15,1	14,7	14,1	16,5	16,0	15,8	15,6	15,1	14,5	16,9	16,5	16,3	16,0	15,5	14,9
Dpev	18,7	17,7	17,3	16,7	15,7	14,4	19,8	18,7	18,3	17,7	16,6	15,3	20,9	19,8	19,4	18,7	17,6	16,2
Tev	9						10						11					
Pf	101	98,2	97,1	95,4	92,5	88,8	104	101	99,6	97,9	94,9	91,1	106	103	102	100	97,2	93,3
Pat	27,8	30,6	31,8	33,8	37,4	42,3	28,2	31,0	32,2	34,2	37,9	42,8	28,5	31,3	32,6	34,6	38,3	43,4
Qev	17,4	16,9	16,7	16,4	15,9	15,3	17,8	17,4	17,2	16,9	16,3	15,7	18,3	17,8	17,6	17,3	16,8	16,1
Dpev	22,0	20,9	20,4	19,7	18,5	17,1	23,2	22,0	21,5	20,8	19,5	18,0	24,4	23,1	22,6	21,8	20,5	18,9

Ta [°C] - Air temperature

Tev [°C] - Plant (side) cooling exchanger output water temperature

Pat [kW] - Total power input

Qev [m³/h] - Plant (side) heat exchanger water flow

Dpev [kPa] - Plant (side) cooling exchanger pressure drop

Pf [kW] - Cooling capacity

'-' Conditions outside the operating range

Waterflow and pressure drop on heat exchangers calculated with 5°C of delta T

NOTE: Data on grey background: unit switched to non-silenced operation

9. HEAT PUMP CAPACITY PERFORMANCE

AWR-HT / CA-E

0122																		
Ta	-20	-15	-12	-5	0	7	-20	-15	-12	-5	0	7	-20	-15	-12	-5	0	7
Tcd	35						45						50					
Pt	18,0	21,4	23,5	28,8	32,7	38,6	20,7	23,2	24,9	29,4	33,1	39,0	-	23,6	25,3	29,9	33,7	39,5
Qcd	1,95	2,32	2,55	3,11	3,54	4,17	2,24	2,52	2,70	3,19	3,60	4,23	-	2,56	2,75	3,25	3,66	4,30
Pcd	0,893	1,26	1,52	2,28	2,95	4,10	1,18	1,49	1,72	2,40	3,04	4,21	-	1,54	1,78	2,49	3,15	4,34
Pat	8,61	8,58	8,58	8,64	8,72	8,90	9,49	9,76	9,91	10,2	10,4	10,7	-	10,3	10,6	11,2	11,5	11,8
Ta	-20	-15	-12	-5	0	7	-20	-15	-12	-5	0	7	-20	-15	-12	-5	0	7
Tcd	55						60						65					
Pt	-	23,6	25,6	30,5	34,4	40,2	-	-	25,6	31,2	35,3	41,0	-	-	25,5	32,1	36,4	42,1
Qcd	-	2,57	2,78	3,33	3,75	4,38	-	-	2,80	3,41	3,85	4,48	-	-	2,79	3,51	3,99	4,60
Pcd	-	1,55	1,82	2,60	3,30	4,50	-	-	1,84	2,73	3,49	4,72	-	-	1,83	2,89	3,73	4,98
Pat	-	10,9	11,4	12,2	12,7	13,1	-	-	12,1	13,4	14,0	14,5	-	-	12,9	14,6	15,4	16,1
0152																		
Ta	-20	-15	-12	-5	0	7	-20	-15	-12	-5	0	7	-20	-15	-12	-5	0	7
Tcd	35						45						50					
Pt	19,9	25,9	29,5	37,8	43,7	51,9	20,9	26,9	30,5	38,8	44,6	52,6	-	27,6	31,1	39,3	45,0	52,9
Qcd	2,15	2,80	3,19	4,09	4,73	5,62	2,26	2,92	3,31	4,21	4,84	5,71	-	3,00	3,38	4,27	4,89	5,75
Pcd	0,748	1,27	1,65	2,71	3,63	5,12	0,831	1,38	1,78	2,87	3,79	5,28	-	1,46	1,86	2,95	3,88	5,36
Pat	10,1	10,6	10,9	11,5	11,9	12,2	10,4	11,6	12,2	13,3	13,9	14,4	-	12,6	13,2	14,4	15,1	15,7
Ta	-20	-15	-12	-5	0	7	-20	-15	-12	-5	0	7	-20	-15	-12	-5	0	7
Tcd	55						60						65					
Pt	-	28,4	31,8	39,8	45,4	53,2	-	-	32,6	40,3	45,8	53,4	-	-	33,5	40,9	46,2	53,6
Qcd	-	3,09	3,47	4,33	4,95	5,79	-	-	3,56	4,40	5,00	5,83	-	-	3,66	4,47	5,05	5,86
Pcd	-	1,55	1,95	3,04	3,96	5,43	-	-	2,05	3,14	4,05	5,50	-	-	2,17	3,24	4,13	5,57
Pat	-	13,9	14,5	15,7	16,3	17,0	-	-	16,0	17,0	17,7	18,5	-	-	17,8	18,5	19,1	20,0
0202																		
Ta	-20	-15	-12	-5	0	7	-20	-15	-12	-5	0	7	-20	-15	-12	-5	0	7
Tcd	35						45						50					
Pt	33,0	38,7	42,4	51,6	58,8	69,7	34,2	39,9	43,6	52,8	59,9	70,6	-	40,4	44,2	53,5	60,6	71,3
Qcd	3,57	4,19	4,59	5,59	6,37	7,55	3,71	4,34	4,73	5,73	6,50	7,66	-	4,39	4,80	5,82	6,59	7,75
Pcd	1,30	1,79	2,15	3,19	4,13	5,81	1,41	1,92	2,29	3,35	4,31	5,99	-	1,97	2,35	3,45	4,44	6,13
Pat	14,8	15,0	15,2	15,6	15,9	16,3	16,7	17,2	17,5	18,2	18,7	19,4	-	18,1	18,6	19,6	20,3	21,2
Ta	-20	-15	-12	-5	0	7	-20	-15	-12	-5	0	7	-20	-15	-12	-5	0	7
Tcd	55						60						65					
Pt	-	40,7	44,7	54,3	61,5	72,2	-	-	45,2	55,2	62,6	73,2	-	-	45,6	56,2	63,8	74,4
Qcd	-	4,44	4,87	5,92	6,70	7,86	-	-	4,93	6,02	6,83	7,99	-	-	4,99	6,14	6,97	8,14
Pcd	-	2,01	2,42	3,57	4,58	6,31	-	-	2,48	3,70	4,76	6,52	-	-	2,54	3,85	4,96	6,76
Pat	-	18,8	19,6	21,1	22,1	23,2	-	-	20,5	22,7	24,0	25,4	-	-	21,4	24,3	26,0	27,7
0262																		
Ta	-20	-15	-12	-5	0	7	-20	-15	-12	-5	0	7	-20	-15	-12	-5	0	7
Tcd	35						45						50					
Pt	43,8	49,1	52,9	63,2	72,0	86,2	45,6	51,0	54,7	64,9	73,5	87,3	-	52,3	56,0	66,0	74,5	88,0
Qcd	4,74	5,31	5,72	6,84	7,79	9,32	4,95	5,53	5,94	7,05	7,98	9,48	-	5,68	6,09	7,18	8,10	9,57
Pcd	1,88	2,37	2,75	3,93	5,10	7,30	2,05	2,57	2,96	4,17	5,35	7,54	-	2,71	3,11	4,33	5,51	7,70
Pat	17,8	18,0	18,2	18,6	19,1	19,9	20,3	20,8	21,1	21,9	22,5	23,6	-	22,5	22,9	23,8	24,6	25,8
Ta	-20	-15	-12	-5	0	7	-20	-15	-12	-5	0	7	-20	-15	-12	-5	0	7
Tcd	55						60						65					
Pt	-	53,9	57,5	67,3	75,6	88,9	-	-	59,2	68,7	76,8	89,9	-	-	61,1	70,3	78,2	91,0
Qcd	-	5,87	6,26	7,33	8,23	9,69	-	-	6,46	7,50	8,39	9,81	-	-	6,69	7,69	8,55	9,96
Pcd	-	2,89	3,29	4,51	5,69	7,88	-	-	3,50	4,73	5,91	8,09	-	-	3,76	4,97	6,15	8,33
Pat	-	24,4	24,9	26,0	26,9	28,2	-	-	27,1	28,4	29,4	30,8	-	-	29,6	31,0	32,1	33,7
0302																		
Ta	-20	-15	-12	-5	0	7	-20	-15	-12	-5	0	7	-20	-15	-12	-5	0	7
Tcd	35						45						50					
Pt	52,7	59,2	63,7	76,2	86,7	104	51,8	59,5	64,5	77,8	88,4	105	-	59,8	65,2	78,8	89,5	106
Qcd	5,70	6,40	6,89	8,24	9,38	11,2	5,62	6,46	7,01	8,44	9,59	11,4	-	6,50	7,09	8,57	9,73	11,5
Pcd	2,37	2,99	3,47	4,96	6,42	9,18	2,31	3,04	3,58	5,20	6,72	9,45	-	3,09	3,66	5,36	6,91	9,67
Pat	20,8	21,0	21,1	21,7	22,2	23,2	25,1	25,2	25,3	25,9	26,5	27,7	-	26,6	27,1	28,2	29,1	30,5
Ta	-20	-15	-12	-5	0	7	-20	-15	-12	-5	0	7	-20	-15	-12	-5	0	7
Tcd	55						60						65					
Pt	-	60,2	65,9	80,0	90,8	107	-	-	66,7	81,3	92,4	109	-	-	67,7	82,8	94,1	111
Qcd	-	6,56	7,18	8,71	9,90	11,7	-	-	7,28	8,88	10,1	11,9	-	-	7,40	9,06	10,3	12,1
Pcd	-	3,14	3,76	5,54	7,15	9,95	-	-	3,87	5,75	7,42	10,3	-	-	4,00	5,99	7,73	10,7
Pat	-	27,6	28,5	30,5	31,9	33,6	-	-	29,8	33,0	34,9	37,1	-	-	30,8	35,5	38,2	40,9

Ta [°C] - Air temperature

Tcd (°C) - Plant (side) heating exchanger output water temperature

Pt (kW) - Heating capacity

Pat (kW) - Total power input

Qcd (m³/h) - Plant (side) heating exchanger water flow

Dp_{cd} (kPa) - Plant (side) heating exchanger pressure drop

⊘ - Conditions outside the operating range

Waterflow and pressure drop on heat exchangers calculated with 8°C of delta T

NOTE: Data on grey background: unit switched to non-silenced operation

9. HEAT PUMP CAPACITY PERFORMANCE

AWR-HT / LN-CA-E

0122																		
Ta	-20	-15	-12	-5	0	7	-20	-15	-12	-5	0	7	-20	-15	-12	-5	0	7
Tcd	35						45						50					
Pt	19,0	22,1	24,0	29,1	33,0	39,0	20,2	23,0	24,9	29,7	33,5	39,4	-	23,3	25,2	30,1	34,0	39,9
Qcd	2,05	2,39	2,60	3,15	3,57	4,22	2,19	2,50	2,70	3,22	3,63	4,28	-	2,53	2,74	3,28	3,70	4,34
Pcd	0,990	1,34	1,59	2,33	3,00	4,19	1,13	1,47	1,71	2,43	3,10	4,30	-	1,51	1,77	2,52	3,21	4,42
Pat	8,61	8,58	8,58	8,64	8,72	8,90	9,49	9,76	9,91	10,2	10,4	10,7	-	10,3	10,6	11,2	11,5	11,8
Ta	-20	-15	-12	-5	0	7	-20	-15	-12	-5	0	7	-20	-15	-12	-5	0	7
Tcd	55						60						65					
Pt	-	23,4	25,5	30,8	34,7	40,6	-	-	25,8	31,5	35,6	41,5	-	-	26,0	32,4	36,7	42,5
Qcd	-	2,55	2,78	3,35	3,78	4,42	-	-	2,82	3,44	3,89	4,53	-	-	2,85	3,54	4,02	4,65
Pcd	-	1,53	1,82	2,64	3,36	4,59	-	-	1,87	2,78	3,55	4,81	-	-	1,91	2,95	3,79	5,08
Pat	-	10,9	11,4	12,2	12,7	13,1	-	-	12,1	13,4	14,0	14,5	-	-	12,9	14,6	15,4	16,1
0152																		
Ta	-20	-15	-12	-5	0	7	-20	-15	-12	-5	0	7	-20	-15	-12	-5	0	7
Tcd	35						45						50					
Pt	22,6	27,4	30,5	37,9	43,4	51,6	22,8	28,0	31,2	38,7	44,3	52,3	-	28,6	31,7	39,2	44,7	52,6
Qcd	2,44	2,97	3,30	4,10	4,70	5,58	2,48	3,04	3,38	4,20	4,81	5,68	-	3,11	3,45	4,27	4,86	5,72
Pcd	0,965	1,43	1,76	2,72	3,57	5,04	0,993	1,49	1,85	2,86	3,75	5,23	-	1,57	1,93	2,95	3,83	5,31
Pat	9,97	10,5	10,8	11,4	11,8	12,1	10,3	11,5	12,1	13,2	13,8	14,3	-	12,5	13,1	14,3	15,0	15,6
Ta	-20	-15	-12	-5	0	7	-20	-15	-12	-5	0	7	-20	-15	-12	-5	0	7
Tcd	55						60						65					
Pt	-	29,5	32,5	39,7	45,1	52,9	-	-	33,4	40,3	45,5	53,1	-	-	34,5	40,9	45,8	53,2
Qcd	-	3,21	3,54	4,33	4,92	5,76	-	-	3,65	4,40	4,97	5,80	-	-	3,77	4,48	5,02	5,82
Pcd	-	1,67	2,03	3,04	3,91	5,38	-	-	2,15	3,14	4,00	5,44	-	-	2,30	3,24	4,08	5,50
Pat	-	13,8	14,4	15,6	16,2	16,9	-	-	15,9	16,9	17,6	18,4	-	-	17,7	18,4	19,0	19,9
0202																		
Ta	-20	-15	-12	-5	0	7	-20	-15	-12	-5	0	7	-20	-15	-12	-5	0	7
Tcd	35						45						50					
Pt	32,2	38,5	42,5	52,2	59,5	70,3	32,6	39,2	43,3	53,1	60,5	71,2	-	39,7	43,9	53,8	61,2	71,8
Qcd	3,49	4,17	4,59	5,64	6,44	7,61	3,53	4,25	4,70	5,77	6,56	7,73	-	4,32	4,77	5,85	6,66	7,81
Pcd	1,24	1,77	2,15	3,25	4,22	5,90	1,27	1,84	2,25	3,39	4,40	6,09	-	1,90	2,32	3,50	4,52	6,22
Pat	14,8	15,0	15,2	15,6	15,9	16,3	16,7	17,2	17,5	18,2	18,7	19,4	-	18,3	18,7	19,7	20,4	21,2
Ta	-20	-15	-12	-5	0	7	-20	-15	-12	-5	0	7	-20	-15	-12	-5	0	7
Tcd	55						60						65					
Pt	-	40,4	44,6	54,7	62,1	72,6	-	-	45,6	55,7	63,1	73,6	-	-	46,6	56,9	64,3	74,7
Qcd	-	4,40	4,86	5,96	6,76	7,91	-	-	4,97	6,08	6,89	8,03	-	-	5,10	6,22	7,03	8,17
Pcd	-	1,98	2,41	3,62	4,66	6,39	-	-	2,52	3,77	4,84	6,58	-	-	2,65	3,95	5,04	6,81
Pat	-	19,4	20,0	21,3	22,2	23,2	-	-	21,4	23,1	24,1	25,4	-	-	22,8	25,0	26,2	27,7
0262																		
Ta	-20	-15	-12	-5	0	7	-20	-15	-12	-5	0	7	-20	-15	-12	-5	0	7
Tcd	35						45						50					
Pt	43,4	49,3	53,3	64,1	73,0	87,1	44,2	50,5	54,6	65,6	74,4	88,2	-	51,2	55,5	66,5	75,3	88,9
Qcd	4,69	5,34	5,77	6,94	7,90	9,43	4,80	5,48	5,93	7,12	8,07	9,57	-	5,57	6,03	7,23	8,19	9,67
Pcd	1,85	2,39	2,80	4,05	5,24	7,47	1,94	2,52	2,96	4,25	5,48	7,69	-	2,60	3,06	4,40	5,63	7,85
Pat	16,4	17,2	17,6	18,6	19,2	20,0	18,9	19,9	20,5	21,8	22,7	23,7	-	22,0	22,6	23,8	24,7	25,9
Ta	-20	-15	-12	-5	0	7	-20	-15	-12	-5	0	7	-20	-15	-12	-5	0	7
Tcd	55						60						65					
Pt	-	52,0	56,4	67,7	76,4	89,8	-	-	57,5	69,0	77,7	90,8	-	-	58,7	70,4	79,2	91,9
Qcd	-	5,67	6,15	7,37	8,33	9,78	-	-	6,28	7,53	8,48	9,91	-	-	6,42	7,71	8,66	10,1
Pcd	-	2,70	3,18	4,56	5,82	8,03	-	-	3,31	4,76	6,05	8,25	-	-	3,47	4,99	6,30	8,49
Pat	-	24,5	25,0	26,1	27,0	28,3	-	-	27,8	28,6	29,5	30,9	-	-	31,0	31,4	32,2	33,8
0302																		
Ta	-20	-15	-12	-5	0	7	-20	-15	-12	-5	0	7	-20	-15	-12	-5	0	7
Tcd	35						45						50					
Pt	55,2	60,3	64,1	75,3	85,3	102	57,1	62,2	66,0	77,1	86,9	103	-	63,2	67,1	78,3	88,0	104
Qcd	5,97	6,52	6,94	8,15	9,23	11,0	6,20	6,75	7,17	8,37	9,43	11,2	-	6,87	7,30	8,51	9,57	11,3
Pcd	2,61	3,11	3,51	4,85	6,21	8,88	2,81	3,33	3,75	5,11	6,49	9,15	-	3,45	3,89	5,29	6,69	9,37
Pat	23,1	22,4	22,1	21,8	22,1	23,0	25,0	25,1	25,2	25,8	26,4	27,6	-	26,5	27,0	28,1	29,0	30,4
Ta	-20	-15	-12	-5	0	7	-20	-15	-12	-5	0	7	-20	-15	-12	-5	0	7
Tcd	55						60						65					
Pt	-	64,1	68,2	79,7	89,5	105	-	-	69,4	81,2	91,1	107	-	-	70,6	83,0	93,0	109
Qcd	-	6,99	7,43	8,68	9,75	11,5	-	-	7,58	8,87	9,95	11,7	-	-	7,73	9,08	10,2	11,9
Pcd	-	3,56	4,03	5,50	6,94	9,64	-	-	4,19	5,74	7,22	9,97	-	-	4,36	6,01	7,56	10,4
Pat	-	28,1	28,8	30,5	31,7	33,4	-	-	30,8	33,2	34,7	36,8	-	-	32,8	36,0	38,0	40,4

Ta [°C] - Air temperature

Tcd (°C) - Plant (side) heating exchanger output water temperature

Pt (kW) - Heating capacity

Pat (kW) - Total power input

Qcd (m³/h) - Plant (side) heating exchanger water flow

Dp_{cd} (kPa) - Plant (side) heating exchanger pressure drop

↕ - Conditions outside the operating range

Waterflow and pressure drop on heat exchangers calculated with 8°C of delta T

NOTE: Data on grey background: unit switched to non-silenced operation

10. DESUPERHEATER CAPACITY PERFORMANCE

AWR-HT-D / CA-E

0122																		
Tde	35	40	45	35	40	45	35	40	45	35	40	45	35	40	45	35	40	45
Ta	30			35			40			45			50			55		
Pf	36,3	36,3	36,3	35,4	35,4	35,4	34,4	34,4	34,4	33,5	33,5	33,5	32,6	32,6	32,6	31,6	31,6	31,6
Pat	10,1	10,1	10,1	11,2	11,2	11,2	12,5	12,5	12,5	13,9	13,9	13,9	15,5	15,5	15,5	17,2	17,2	17,2
Ptde	9,14	8,68	8,22	10,2	9,97	9,46	11,5	11,5	10,9	12,9	13,2	12,6	14,5	15,2	14,5	16,2	17,4	16,6
Qde	1,58	1,51	1,43	1,77	1,73	1,64	1,99	1,99	1,90	2,23	2,29	2,19	2,51	2,64	2,52	2,81	3,02	2,89
Dpde	2,56	2,32	2,09	3,21	3,07	2,77	4,05	4,06	3,68	5,11	5,39	4,89	6,44	7,12	6,48	8,07	9,36	8,54

0152																		
Tde	35	40	45	35	40	45	35	40	45	35	40	45	35	40	45	35	40	45
Ta	30			35			40			45			50			55		
Pf	46,5	46,5	46,5	45,4	45,4	45,4	44,2	44,2	44,2	42,8	42,8	42,8	41,2	41,2	41,2	39,4	39,4	39,4
Pat	13,1	13,1	13,1	14,2	14,2	14,2	15,5	15,5	15,5	16,8	16,8	16,8	18,3	18,3	18,3	19,8	19,8	19,8
Ptde	11,6	11,0	10,4	12,7	12,4	11,8	14,0	14,0	13,3	15,3	15,7	15,0	16,8	17,6	16,8	18,3	19,7	18,8
Qde	2,01	1,91	1,81	2,21	2,15	2,05	2,42	2,43	2,31	2,66	2,73	2,60	2,91	3,06	2,92	3,18	3,42	3,27
Dpde	4,12	3,73	3,36	4,98	4,75	4,29	6,01	6,03	5,46	7,23	7,62	6,92	8,66	9,58	8,72	10,3	12,0	10,9

0202																		
Tde	35	40	45	35	40	45	35	40	45	35	40	45	35	40	45	35	40	45
Ta	30			35			40			45			50			55		
Pf	64,2	64,2	64,2	62,6	62,6	62,6	61,0	61,0	61,0	59,5	59,5	59,5	58,0	58,0	58,0	56,5	56,5	56,5
Pat	18,0	18,0	18,0	19,8	19,8	19,8	21,7	21,7	21,7	23,8	23,8	23,8	26,0	26,0	26,0	28,4	28,4	28,4
Ptde	16,0	15,2	14,4	17,8	17,3	16,4	19,7	19,7	18,7	21,8	22,3	21,2	24,0	25,2	24,0	26,4	28,4	27,1
Qde	2,77	2,63	2,50	3,08	3,00	2,85	3,41	3,42	3,25	3,77	3,87	3,69	4,16	4,38	4,18	4,58	4,93	4,71
Dpde	3,39	3,07	2,76	4,18	3,99	3,60	5,14	5,16	4,67	6,29	6,63	6,02	7,66	8,47	7,71	9,27	10,7	9,80

0262																		
Tde	35	40	45	35	40	45	35	40	45	35	40	45	35	40	45	35	40	45
Ta	30			35			40			45			50			55		
Pf	81,5	81,5	81,5	79,3	79,3	79,3	76,9	76,9	76,9	74,4	74,4	74,4	71,7	71,7	71,7	68,9	68,9	68,9
Pat	22,8	22,8	22,8	25,0	25,0	25,0	27,4	27,4	27,4	30,0	30,0	30,0	33,0	33,0	33,0	36,2	36,2	36,2
Ptde	20,8	19,8	18,7	23,0	22,4	21,2	25,4	25,4	24,1	28,0	28,8	27,3	31,0	32,5	31,0	34,2	36,7	35,0
Qde	3,60	3,43	3,25	3,98	3,88	3,69	4,40	4,40	4,19	4,86	4,99	4,75	5,37	5,64	5,38	5,92	6,37	6,08
Dpde	5,74	5,20	4,68	6,99	6,67	6,02	8,54	8,57	7,76	10,4	11,0	9,98	12,7	14,1	12,8	15,5	17,9	16,4

0302																		
Tde	35	40	45	35	40	45	35	40	45	35	40	45	35	40	45	35	40	45
Ta	30			35			40			45			50			55		
Pf	97,8	97,8	97,8	95,1	95,1	95,1	92,3	92,3	92,3	89,4	89,4	89,4	86,3	86,3	86,3	83,1	83,1	83,1
Pat	27,5	27,5	27,5	30,3	30,3	30,3	33,5	33,5	33,5	37,1	37,1	37,1	41,1	41,1	41,1	45,5	45,5	45,5
Ptde	25,5	24,2	23,0	28,3	27,6	26,2	31,5	31,5	29,9	35,1	35,9	34,2	39,1	41,0	39,1	43,5	46,8	44,6
Qde	4,42	4,20	3,99	4,90	4,78	4,54	5,45	5,46	5,19	6,07	6,23	5,94	6,77	7,12	6,79	7,54	8,12	7,75
Dpde	8,63	7,81	7,03	10,6	10,1	9,13	13,1	13,2	11,9	16,3	17,2	15,6	20,3	22,4	20,4	25,1	29,1	26,6

Tde (°C) - Plant (side) heat exchanger recovery output water temperature
 Ta [°C] - Source (side) cooling exchanger air temperature
 Pf (kW) - Cooling capacity (Plant side cooling exchanger water in/out 12/7 °C)
 Pat (kW) - Total power input
 Ptde (kW) - Heat recovery thermal capacity
 Qde (m³/h) - Plant (side) cooling exchanger recovery water flow
 Dpde (kPa) - Plant side heating exchanger recovery pressure drop
 '-' - Conditions outside the operating range
 Waterflow and pressure drop on heat exchangers calculated with 5°C of delta T
 NOTE: Data on grey background: unit switched to non-silenced operation

10. DESUPERHEATER CAPACITY PERFORMANCE

AWR-HT-D / LN-CA-E

0122																		
Tde	35	40	45	35	40	45	35	40	45	35	40	45	35	40	45			
Ta	30			35			40			45			50			55		
Pf	36,2	36,2	36,2	35,3	35,3	35,3	34,4	34,4	34,4	33,7	33,7	33,7	33,0	33,0	33,0	32,4	32,4	32,4
Pat	10,1	10,1	10,1	11,2	11,2	11,2	12,6	12,6	12,6	14,2	14,2	14,2	16,0	16,0	16,0	18,0	18,0	18,0
Ptde	9,10	8,65	8,19	10,2	9,97	9,46	11,6	11,6	11,0	13,2	13,5	12,8	15,0	15,7	15,0	17,0	18,3	17,4
Qde	1,58	1,50	1,42	1,77	1,73	1,64	2,01	2,01	1,91	2,28	2,34	2,23	2,59	2,72	2,60	2,94	3,17	3,03
Dpde	2,55	2,30	2,08	3,21	3,07	2,77	4,12	4,13	3,74	5,32	5,60	5,09	6,87	7,60	6,92	8,86	10,3	9,37

0152																		
Tde	35	40	45	35	40	45	35	40	45	35	40	45	35	40	45			
Ta	30			35			40			45			50			55		
Pf	46,7	46,7	46,7	45,5	45,5	45,5	44,2	44,2	44,2	42,6	42,6	42,6	40,9	40,9	40,9	38,9	38,9	38,9
Pat	13,2	13,2	13,2	14,4	14,4	14,4	15,8	15,8	15,8	17,3	17,3	17,3	19,0	19,0	19,0	20,8	20,8	20,8
Ptde	11,7	11,2	10,6	12,9	12,6	12,0	14,3	14,3	13,6	15,8	16,2	15,4	17,5	18,3	17,5	19,3	20,7	19,8
Qde	2,03	1,93	1,84	2,24	2,19	2,08	2,47	2,48	2,36	2,74	2,81	2,68	3,03	3,18	3,04	3,34	3,60	3,44
Dpde	4,23	3,83	3,45	5,14	4,90	4,42	6,27	6,29	5,69	7,66	8,08	7,33	9,37	10,4	9,43	11,4	13,3	12,1

0202																		
Tde	35	40	45	35	40	45	35	40	45	35	40	45	35	40	45			
Ta	30			35			40			45			50			55		
Pf	64,0	64,0	64,0	62,5	62,5	62,5	60,9	60,9	60,9	59,4	59,4	59,4	57,9	57,9	57,9	56,4	56,4	56,4
Pat	18,1	18,1	18,1	19,9	19,9	19,9	21,8	21,8	21,8	23,9	23,9	23,9	26,1	26,1	26,1	28,5	28,5	28,5
Ptde	16,1	15,3	14,5	17,9	17,4	16,5	19,8	19,8	18,8	21,9	22,4	21,3	24,1	25,3	24,1	26,5	28,5	27,2
Qde	2,79	2,65	2,52	3,09	3,02	2,87	3,43	3,43	3,27	3,79	3,89	3,71	4,18	4,39	4,19	4,60	4,95	4,73
Dpde	3,43	3,11	2,80	4,23	4,03	3,64	5,19	5,21	4,71	6,34	6,69	6,07	7,72	8,54	7,77	9,34	10,8	9,88

0262																		
Tde	35	40	45	35	40	45	35	40	45	35	40	45	35	40	45			
Ta	30			35			40			45			50			55		
Pf	81,3	81,3	81,3	79,1	79,1	79,1	76,7	76,7	76,7	74,1	74,1	74,1	71,5	71,5	71,5	68,7	68,7	68,7
Pat	23,0	23,0	23,0	25,3	25,3	25,3	27,7	27,7	27,7	30,3	30,3	30,3	33,1	33,1	33,1	36,1	36,1	36,1
Ptde	21,0	20,0	18,9	23,3	22,7	21,5	25,7	25,7	24,4	28,3	29,0	27,6	31,1	32,6	31,1	34,1	36,6	34,9
Qde	3,64	3,47	3,29	4,03	3,93	3,74	4,45	4,45	4,24	4,90	5,03	4,79	5,38	5,66	5,40	5,90	6,35	6,07
Dpde	5,87	5,31	4,78	7,17	6,84	6,18	8,74	8,76	7,94	10,6	11,2	10,1	12,8	14,2	12,9	15,4	17,8	16,3

0302																		
Tde	35	40	45	35	40	45	35	40	45	35	40	45	35	40	45			
Ta	30			35			40			45			50			55		
Pf	96,6	96,6	96,6	93,8	93,8	93,8	90,9	90,9	90,9	87,8	87,8	87,8	84,7	84,7	84,7	81,3	81,3	81,3
Pat	28,8	28,8	28,8	31,8	31,8	31,8	35,2	35,2	35,2	39,0	39,0	39,0	43,1	43,1	43,1	47,6	47,6	47,6
Ptde	26,8	25,5	24,1	29,8	29,1	27,6	33,2	33,2	31,5	37,0	37,9	36,0	41,1	43,2	41,1	45,6	49,1	46,8
Qde	4,65	4,42	4,20	5,16	5,04	4,79	5,75	5,76	5,48	6,40	6,57	6,26	7,12	7,49	7,14	7,91	8,51	8,13
Dpde	9,54	8,64	7,78	11,8	11,2	10,2	14,6	14,7	13,3	18,1	19,1	17,3	22,4	24,8	22,6	27,6	32,0	29,2

Tde (°C) - Plant (side) heat exchanger recovery output water temperature
 Ta [°C] - Source (side) cooling exchanger air temperature
 Pf (kW) - Cooling capacity (Plant side cooling exchanger water in/out 12/7 °C)
 Pat (kW) - Total power input
 Ptde (kW) - Heat recovery thermal capacity
 Qde (m³/h) - Plant (side) cooling exchanger recovery water flow
 Dpde (kPa) - Plant side heating exchanger recovery pressure drop
 '-' - Conditions outside the operating range
 Waterflow and pressure drop on heat exchangers calculated with 5°C of delta T
 NOTE: Data on grey background: unit switched to non-silenced operation

11. OPERATING LIMITS

AWR-HT / CA-E - 0122 ÷ 0302

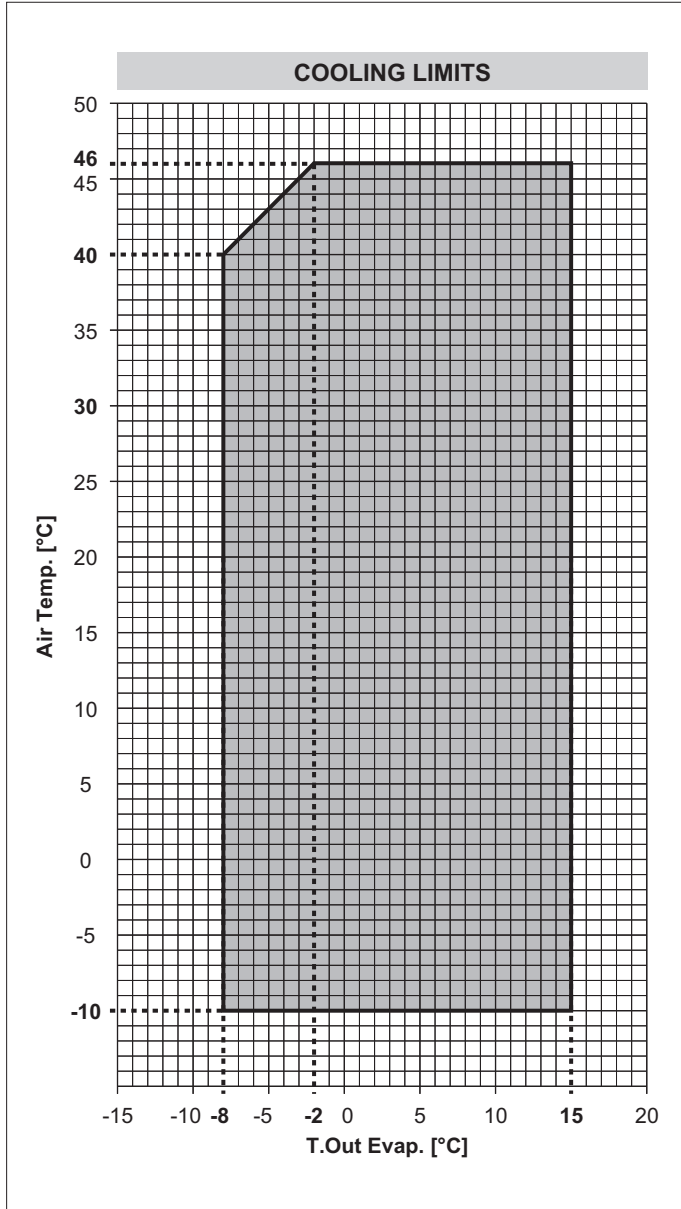

AWR-HT / LN-CA-E - 0122 ÷ 0302

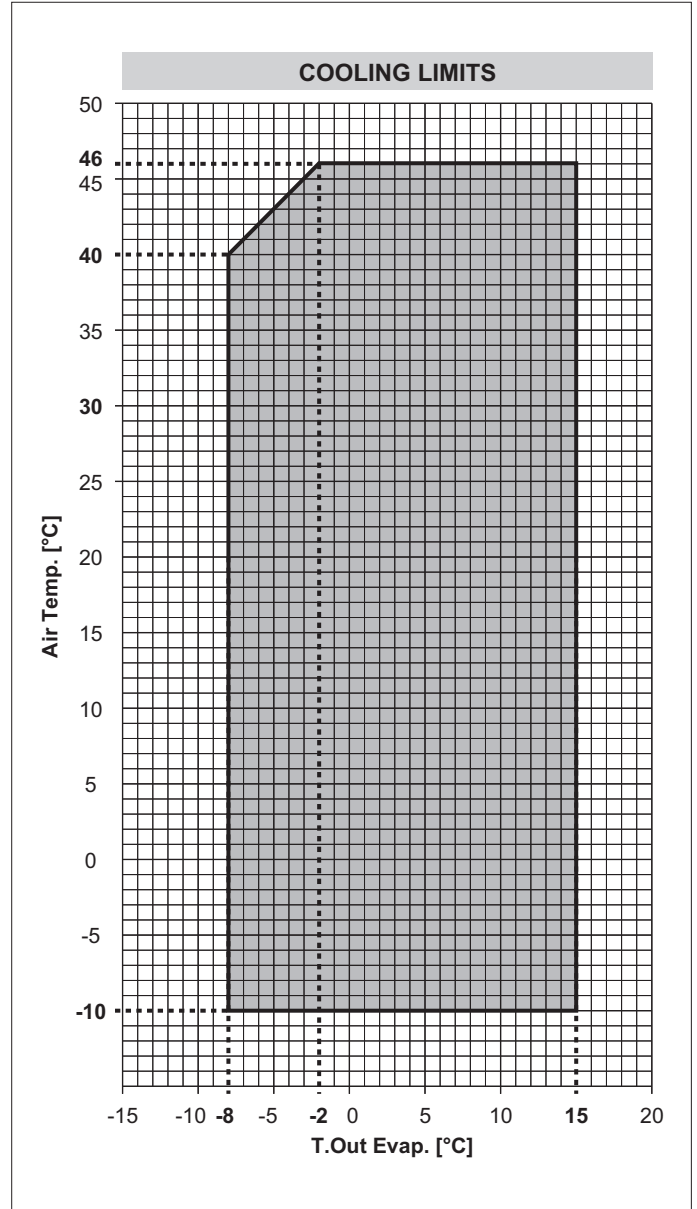

11. OPERATING LIMITS

AWR-HT / CA-E - 0122 ÷ 0302

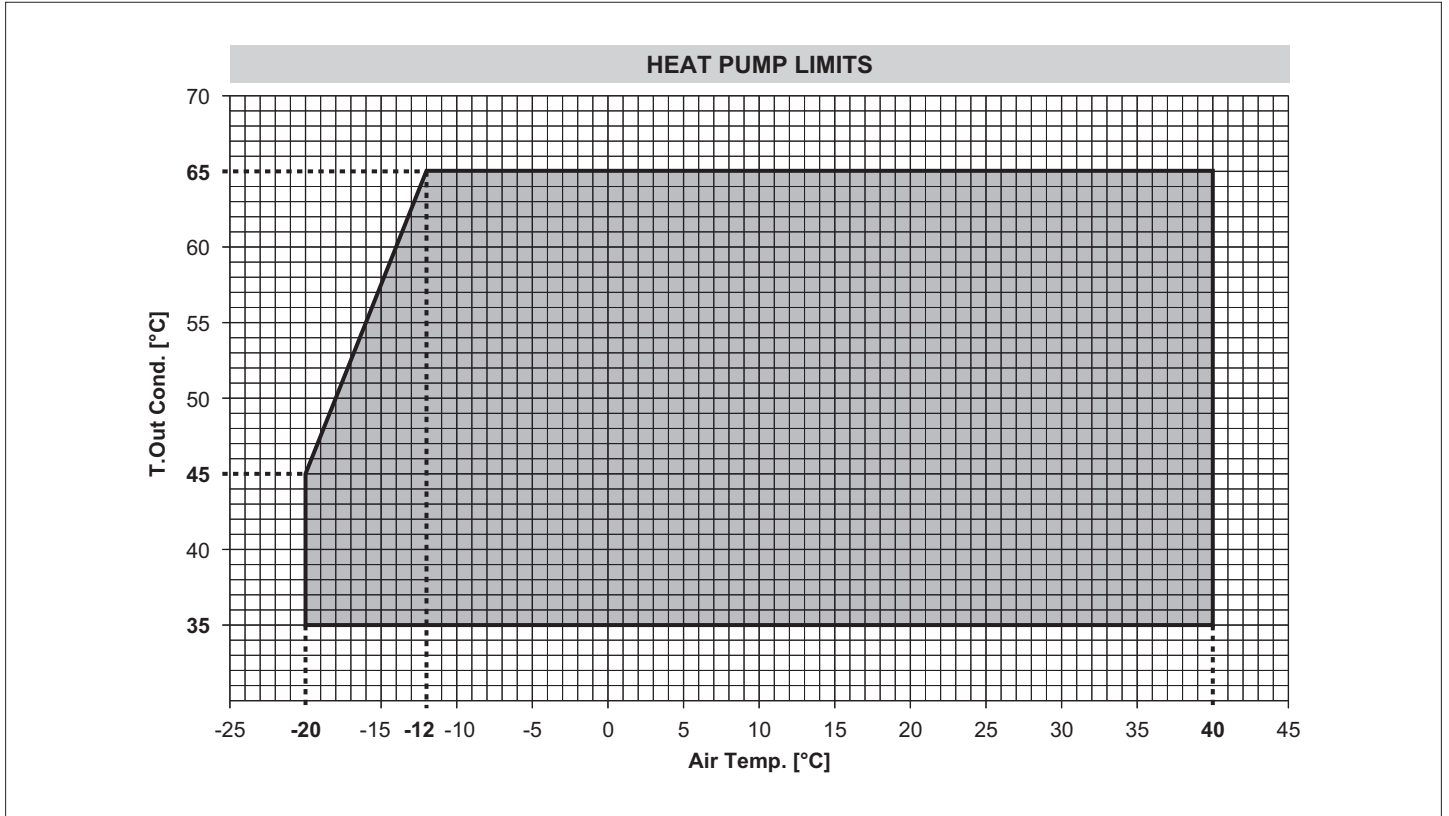

AWR-HT / LN-CA-E - 0122 ÷ 0302

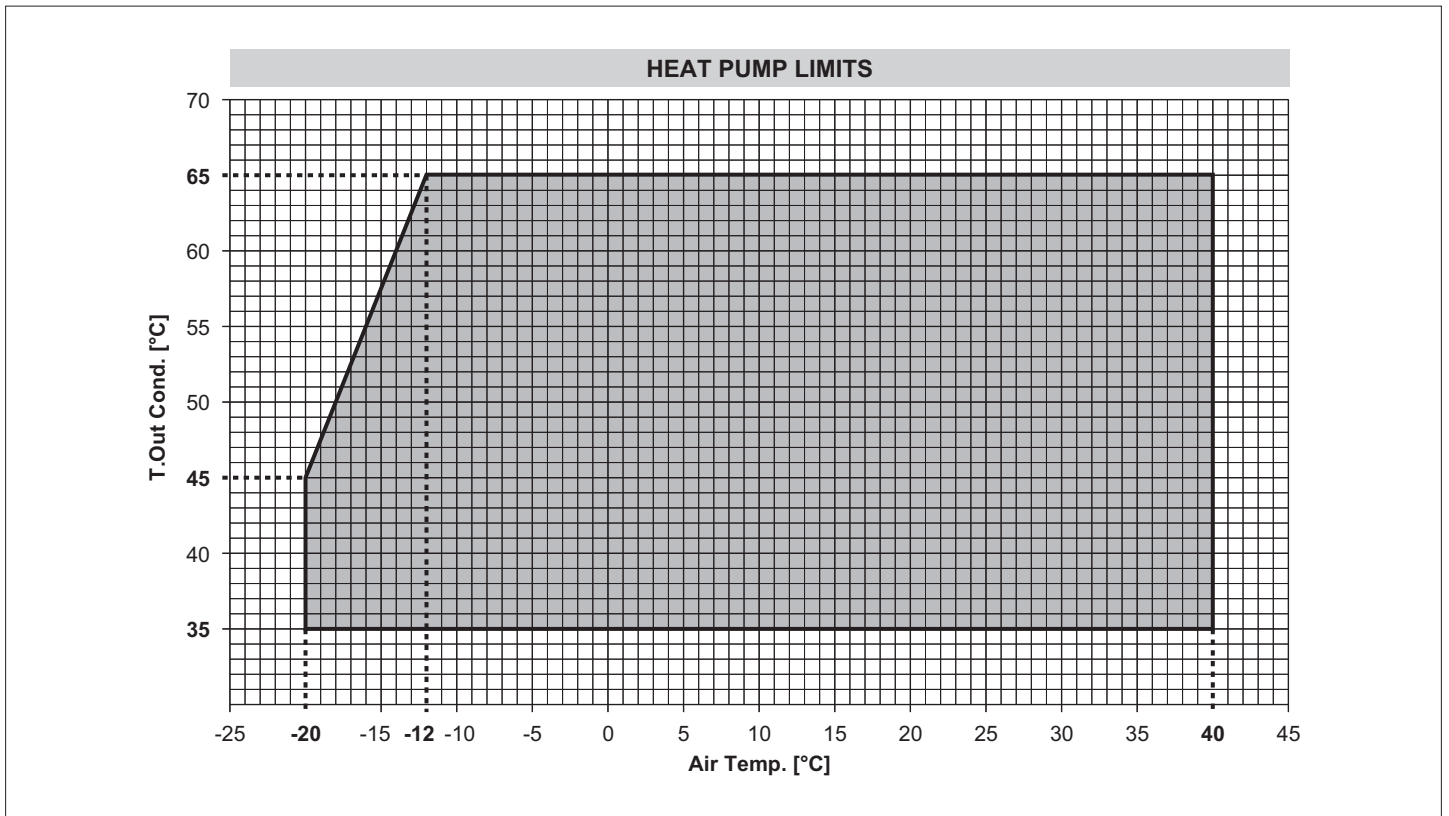

12. ETHYLENE GLYCOL MIXTURE

Ethylene glycol and water mixture, used as a heat-conveying fluid, cause a variation in unit performance. For correct data, use the factors indicated in the following table.

	Freezing point (°C)							
	0	-5	-10	-15	-20	-25	-30	-35
	Ethylene glycol percentage by weight							
	0	12%	20%	30%	35%	40%	45%	50%
cPf	1	0,985	0,98	0,974	0,97	0,965	0,964	0,96
cQ	1	1,02	1,04	1,075	1,11	1,14	1,17	1,2
cdp	1	1,07	1,11	1,18	1,22	1,24	1,27	1,3

cPf: cooling power correction factor
 cQ: flow correction factor
 cdp: pressure drop correction factor

For data concerning other kind of anti-freeze solutions (e.g. propylene glycol) please contact our Sale Department.

13. FOULING FACTORS

Performances are based on clean condition of tubes (fouling factor = 1). For different fouling values, performance should be adjusted using the correction factors shown in the following table.

FOULING FACTORS ff (m °CW)	EVAPORATOR			CONDENSER/RECOVERY			DESUPERHEATER
	F1	FK1	KE [°C]	F2	FK2	KC [°C]	R3
0	1,000	1,000	0,0	1,000	1,000	0,0	1,000
1,80 x 10 ⁻⁵	1,000	1,000	0,0	1,000	1,000	0,0	1,000
4,40 x 10 ⁻⁵	1,000	1,000	0,0	0,990	1,030	1,0	0,990
8,80 x 10 ⁻⁵	0,960	0,990	0,7	0,980	1,040	1,5	0,980
13,20 x 10 ⁻⁵	0,944	0,985	1,0	0,964	1,050	2,3	0,964
17,20 x 10 ⁻⁵	0,930	0,980	1,5	0,950	1,060	3,0	0,950

ff: fouling factors
 f1 - f2: potential correction factors
 fk1 - fk2: compressor power input correction factors
 r3: capacity correction factors

KE: minimum condenser outlet temperature increase
 KC: maximum condenser outlet temperature decrease

14. HYDRAULIC DATA

Water flow and pressure drop

Water flow in the heat exchangers is given by: $Q = P \times 0,86 / Dt$

Q: water flow (m³/h)

Dt: difference between inlet and outlet water temp. (°C)

P: heat exchanger capacity (kW)

Pressure drop is given by: $Dp = K \times Q^2 / 1000$

Q: water flow (m³/h)

Dp: pressure drop (kPa)

K: unit size ratio

SIZE	Plant side heat exchanger					Auxiliary side heat exchanger			
	K	Q min	Q max	C.A.S.	C.a.	K	Q min	C.A.S.	Q max
		m³/h	m³/h	dm³	min m³		m³/h	dm³	m³/h
AWR-HT /CA-E 0122	235	3,3	27,5	7	0,35	-	-	-	-
AWR-HT /CA-E 0152	162	3,3	27,5	10	0,45	-	-	-	-
AWR-HT /CA-E 0202	102	5,3	27,5	13	0,62	-	-	-	-
AWR-HT /CA-E 0262	84	7,4	27,5	16	0,76	-	-	-	-
AWR-HT /CA-E 0302	73	8,6	27,5	19	0,91	-	-	-	-
AWR-HT /LN-CA-E 0122	235	3,3	27,5	7	0,35	-	-	-	-
AWR-HT /LN-CA-E 0152	162	3,3	27,5	10	0,45	-	-	-	-
AWR-HT /LN-CA-E 0202	102	5,3	27,5	13	0,62	-	-	-	-
AWR-HT /LN-CA-E 0262	84	7,4	27,5	16	0,76	-	-	-	-
AWR-HT /LN-CA-E 0302	73	8,6	27,5	19	0,91	-	-	-	-
AWR-HT /D /CA-E 0122	235	3,3	27,5	7	0,35	1024	-	0,3	2
AWR-HT /D /CA-E 0152	162	3,3	27,5	10	0,45	1024	-	0,3	2,6
AWR-HT /D /CA-E 0202	102	5,3	27,5	13	0,62	442	-	0,4	3,5
AWR-HT /D /CA-E 0262	84	7,4	27,5	16	0,76	442	-	0,4	4,6
AWR-HT /D /CA-E 0302	73	8,6	27,5	19	0,91	442	-	0,4	5,8
AWR-HT /D /LN-CA-E 0122	235	3,3	27,5	7	0,35	1024	-	0,3	2
AWR-HT /D /LN-CA-E 0152	162	3,3	27,5	10	0,45	1024	-	0,3	2,6
AWR-HT /D /LN-CA-E 0202	102	5,3	27,5	13	0,62	442	-	0,4	3,5
AWR-HT /D /LN-CA-E 0262	84	7,4	27,5	16	0,76	442	-	0,4	4,6
AWR-HT /D /LN-CA-E 0302	73	8,6	27,5	19	0,91	442	-	0,4	5,8

Q min: minimum water flow admitted to the heat exchanger

Q max: maximum water flow admitted to the heat exchanger

C.a. min: minimum water content admitted in the plant, using traditional control logic

C.A.S.: heat exchanger water content

13. HYDRONIC GROUP (OPTIONAL)

The units can be supplied with a hydronic group. This houses all the main hydraulic components, thereby optimising hydraulic and electric installation space, time and cost.

Available pump configurations:

- Hydronic kit with one IN-LINE 2-pole low-head pump
- Hydronic kit with one IN-LINE 2-pole high-head pump
- Hydronic kit with IN-LINE 2-pole low-head twin pumps
- Hydronic kit with IN-LINE 2-pole high-head twin pumps

2-pole low head pump

Centrifugal pumps with in-line suction and delivery flanges, in single and twin versions. Pump body in cast iron and impeller in AISI 316L stainless steel or cast-iron, entirely laser technology welded. Mechanical seal with components in ceramics, carbon and EPDM elastomers. Three-phase electric motor protected to IP55, insulation class F, suitable for continuous service.

2-pole high-head pump

All versions of the hydronic unit can be supplied with a high head pump. In these cases, the pump features a two-pole motor even in the silent-running versions.

Twin pump

A second stand-by pump for high or low pressures is available on request. The pumps are automatically exchanged on the basis of a rotation programme and the stand-by pump cuts in automatically if the primary pump fails.

GENERAL CHARACTERISTICS

Water connections

In the units without pumps, standard version, the connections for the water inlet and outlet both in the evaporator and in the desuperheater are inside the unit. As an accessory one can request these connections flush with the unit.

For units with pumps, the connections are always flush with the unit.

3 way valve kit

Three way valve for the production of domestic hot water (DHW) including water temperature sensor, voltage-free contact for activating an integrating external heating source (gas boiler or electrical heater). The kit comes with or without the 3 way valve factory built-in.

Water-side mechanical filter (optional)

Y-filter designed and built to capture the impurities in the hydraulic circuit. It is fitted with a 0.9 mm stainless steel mesh cartridge which can be replaced without removing the valve body from the piping.

Unit electrical panel

The unit electrical panel is fitted with fuses and a circuit breaker contactor.

Special pumps

For pumps with different configurations, please contact our sales department.

Additional components

The supply does not include the following accessories though these are recommended to ensure correct system operation:

- MA Pressure gauges upline and downline from the unit
- GF Flexible joints on piping
- RI On-off valves
- T Outlet control thermometer

Extra weight

SIZE	1 Pump Hydronic kit	2 Pumps Hydronic kit
	extra [kg]	extra [kg]
0122 /CA-E	40	70
0152 /CA-E	50	80
0202 /CA-E	60	90
0262 /CA-E	60	90
0302 /CA-E	70	90
0122 /LN-CA-E	40	60
0152 /LN-CA-E	40	70
0202 /LN-CA-E	60	80
0262 /LN-CA-E	60	90
0302 /LN-CA-E	70	100

extra [kg] extra weight

Hydraulic diagram

CIRCUITO DESURRISCALDATORI OPZIONALE
 OPTIONAL DESUPERHEATERS CIRCUIT

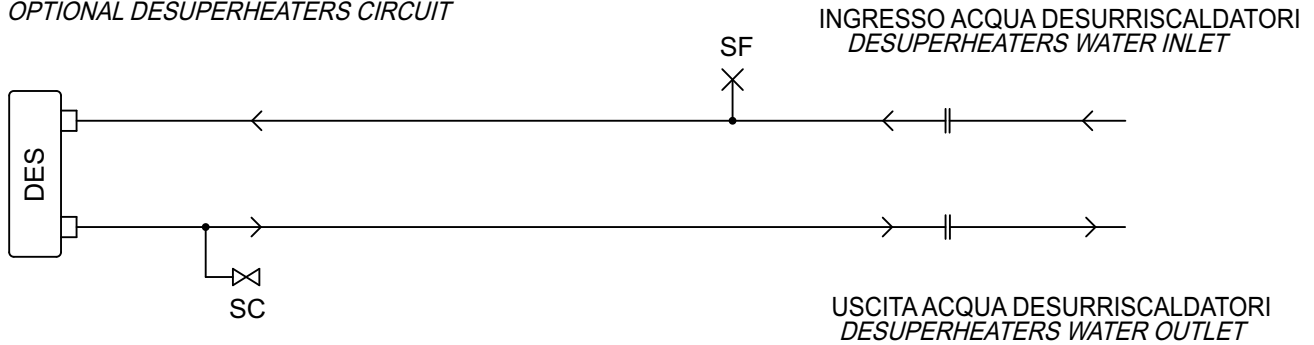

CIRCUITO A 2 POMPE OPZIONALE
 OPZIONAL 2 PUMPS CIRCUIT

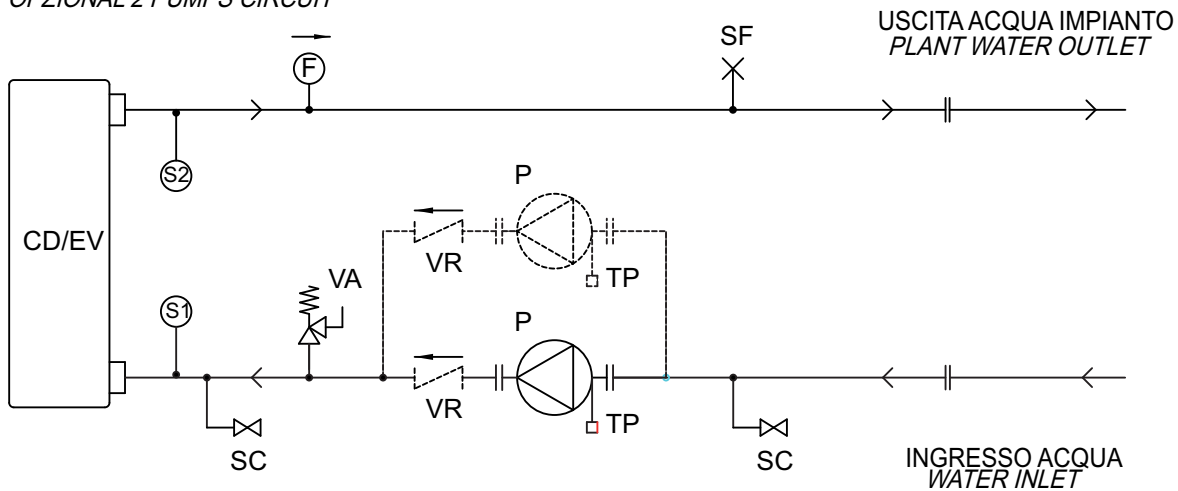

LEGENDA - LEGEND

CD/EV	Evaporatore/Condensatore (scambiatore a piastre) Evaporator/Condenser (plate exchanger)
DES	Desurriscaldatori opzionali (scambiatore a piastre) Desuperheaters optional (plate exchanger)
F	Flussostato Flow switch
P	Pompa di circolazione Available pressure pump
SC	Valvola di scarico Drain valve
SF	Valvola di sfianto Purge valve
S1	Sonda ingresso acqua scambiatore Exchanger water inlet probe
S2	Sonda uscita acqua scambiatore Exchanger water outlet probe
TP	Tappo di drenaggio Drain plug
VA	Valvola di sicurezza Safety valve
VR	Valvola di ritegno (solo con 2 pompe) Check valve (only with 2 pumps)

Hydraulic diagram with 3 way valve

CIRCUITO DESURRISCALDATORI OPZIONALE
 OPTIONAL DESUPERHEATERS CIRCUIT

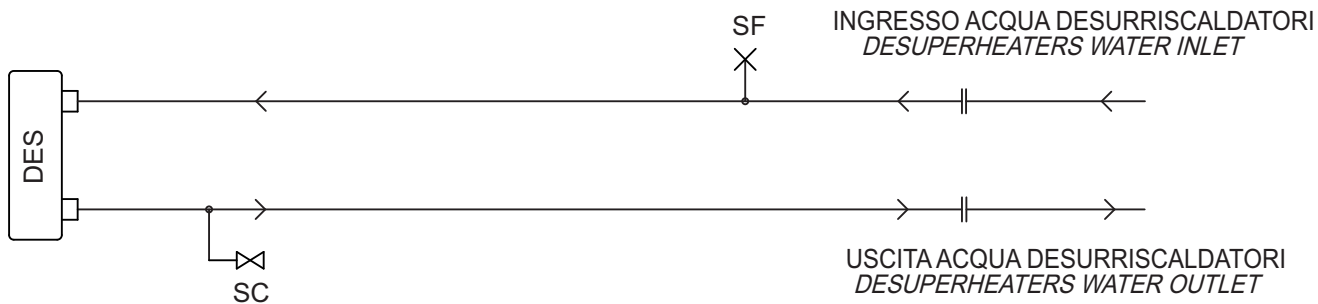

CIRCUITO A 2 POMPE OPZIONALE
 OPZIONAL 2 PUMPS CIRCUIT

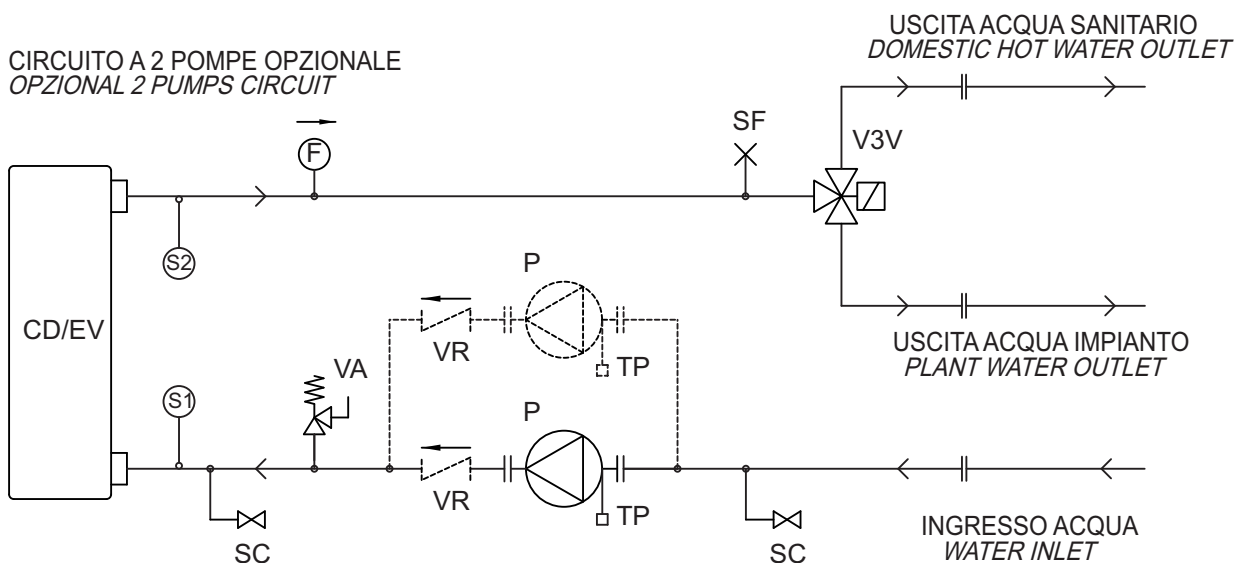

LEGENDA - LEGEND

CD/EV	Evaporatore/Condensatore (scambiatore a piastre) Evaporator/Condenser (plate exchanger)
DES	Desurriscaldatori opzionali (scambiatore a piastre) Desuperheaters optional (plate exchanger)
F	Flussostato Flow switch
P	Pompa di circolazione Available pressure pump
SC	Valvola di scarico Drain valve
SF	Valvola di sfiato Purge valve
S1	Sonda ingresso acqua scambiatore Exchanger water inlet probe
S2	Sonda uscita acqua scambiatore Exchanger water outlet probe
TP	Tappo di drenaggio Drain plug
VA	Valvola di sicurezza Safety valve
VR	Valvola di ritegno (solo con 2 pompe) Check valve (only with 2 pumps)
V3V	Valvole 3 vie 3 way valve

COOLING - 1 PUMP - HIGH HEAD PUMP

	Pf (1)	Q (1)	Rif.	Pump	N.	F.L.I.	F.L.A.	Ks	Dps	Hu		
SIZE	[kW]	[m ³ /h]	Pump	type	Pole	[kW]	[A]	-	kPa	kPa	Kv3v	Kfi
0122	34,1	5,9	C1	DWC-V 300 / 1,5	2	1,5	3,2	294	10,1	211	66	109
0152	43,8	7,5	C2	DWC-V 300 / 1,5	2	1,5	3,2	217	12,3	203	66	109
0202	60,3	10,4	C3	DWC-V 300 / 1,5	2	1,5	3,2	123	13,2	190	27	79
0262	76,4	13,1	E	DWC-V 500 / 2,2	2	2,2	4,8	104	18,0	206	27	79
0302	91,7	15,8	F	DWC-V 500 / 3,0	2	3	5,6	92	22,9	215	27	79

HEATING - 1 PUMP - HIGH HEAD PUMP

	Pt (1)	Q (1)	Rif.	Pump	N.	F.L.I.	F.L.A.	Ks	Dps	Hu		
SIZE	[kW]	[m ³ /h]	Pump	type	Pole	[kW]	[A]	-	kPa	kPa	Kv3v	Kfi
0122	38,0	6,5	C1	DWC-V 300 / 1,5	2	1,5	3,2	294	12,6	206	66	109
0152	51,3	8,8	C2	DWC-V 300 / 1,5	2	1,5	3,2	217	16,9	192	66	109
0202	68,8	11,8	C3	DWC-V 300 / 1,5	2	1,5	3,2	123	17,2	180	27	79
0262	84,9	14,6	E	DWC-V 500 / 2,2	2	2,2	4,8	104	22,2	198	27	79
0302	102,0	17,5	F	DWC-V 500 / 3,0	2	3	5,6	92	28,3	206	27	79

(1) Values refer to rated operating conditions
 Pf Cooling capacity of unit
 Pt Heating capacity of unit
 Q Flow of water to evaporator
 F.L.I. Power absorbed by pump
 F.L.A. Current absorbed by pump

Ks Coefficients for calculating pressure drops
 Unit with hydronic unit without network filter and 3 way valve
 Kv3v Coefficients 3 way valve for calculating pressure drops
 Kfi Coefficients filter for calculating pressure drops
 Dps Total pressure drop of hydronic group
 Hu Residual head

WORKING HEAD CURVES

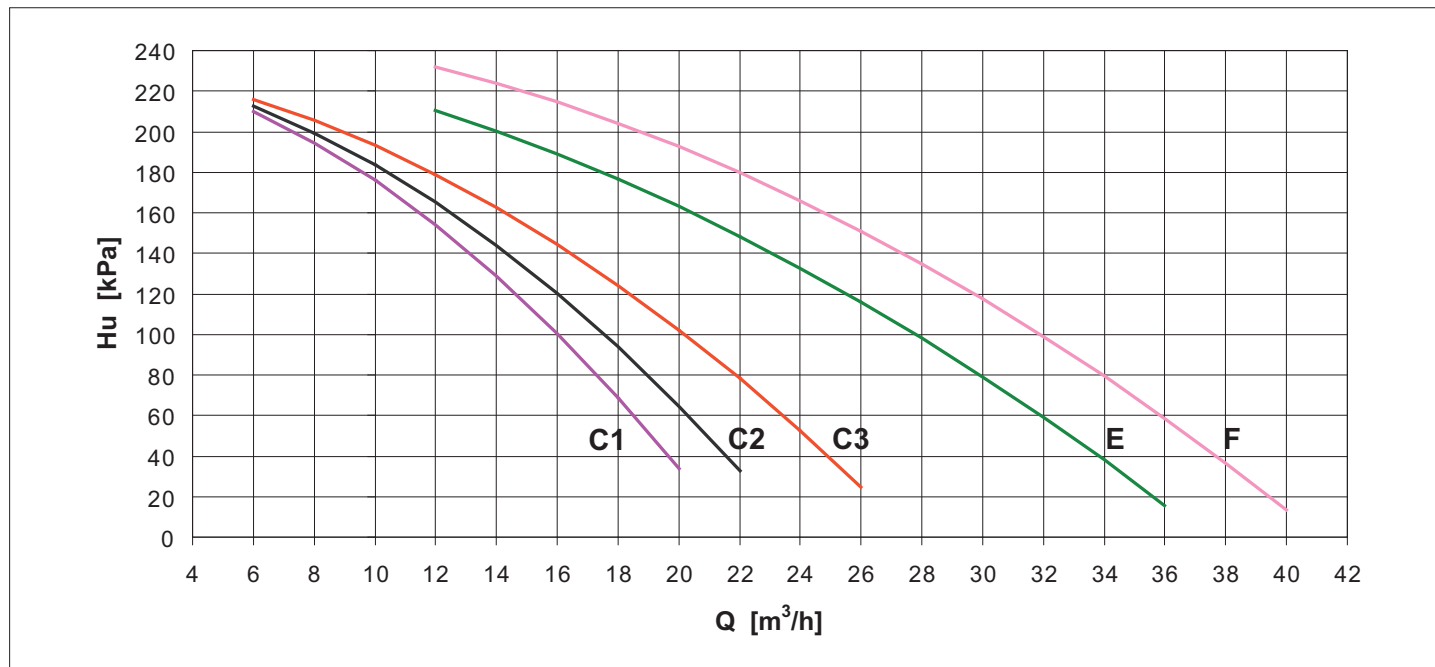

COOLING - 2 PUMPS - HIGH HEAD PUMP

	Pf (1)	Q (1)	Rif.	Pump	N.	F.L.I.	F.L.A.	Ks	Dps	Hu		
SIZE	[kW]	[m³/h]	Pump	type	Pole	[kW]	[A]	-	kPa	kPa	Kv3v	Kfi
0122	34,1	5,9	C1	DWC-V 300 / 1,5	2	1,5	3,2	373	12,8	208	66	109
0152	43,8	7,5	C2	DWC-V 300 / 1,5	2	1,5	3,2	293	16,6	198	66	109
0202	60,3	10,4	C3	DWC-V 300 / 1,5	2	1,5	3,2	153	16,5	187	27	79
0262	76,4	13,1	E	DWC-V 500 / 2,2	2	2,2	4,8	134	23,1	201	27	79
0302	91,7	15,8	F	DWC-V 500 / 3,0	2	3	5,6	122	30,3	208	27	79

HEATING - 2 PUMPS - HIGH HEAD PUMP

	Pt (1)	Q (1)	Rif.	Pump	N.	F.L.I.	F.L.A.	Ks	Dps	Hu		
SIZE	[kW]	[m³/h]	Pump	type	Pole	[kW]	[A]	-	kPa	kPa	Kv3v	Kfi
0122	38,0	6,5	C1	DWC-V 300 / 1,5	2	1,5	3,2	294	15,9	203	66	109
0152	51,3	8,8	C2	DWC-V 300 / 1,5	2	1,5	3,2	217	22,8	186	66	109
0202	68,8	11,8	C3	DWC-V 300 / 1,5	2	1,5	3,2	123	21,4	176	27	79
0262	84,9	14,6	E	DWC-V 500 / 2,2	2	2,2	4,8	104	28,6	191	27	79
0302	102,0	17,5	F	DWC-V 500 / 3,0	2	3	5,6	92	37,6	196	27	79

(1) Values refer to rated operating conditions
 Pf Cooling capacity of unit
 Pt Heating capacity of unit
 Q Flow of water to evaporator
 F.L.I. Power absorbed by pump
 F.L.A. Current absorbed by pump

Ks Coefficients for calculating pressure drops
 Unit with hydronic unit without network filter and 3 way valve
 Kv3v Coefficients 3 way valve for calculating pressure drops
 Kfi Coefficients filter for calculating pressure drops
 Dps Total pressure drop of hydronic group
 Hu Residual head

WORKING HEAD CURVES

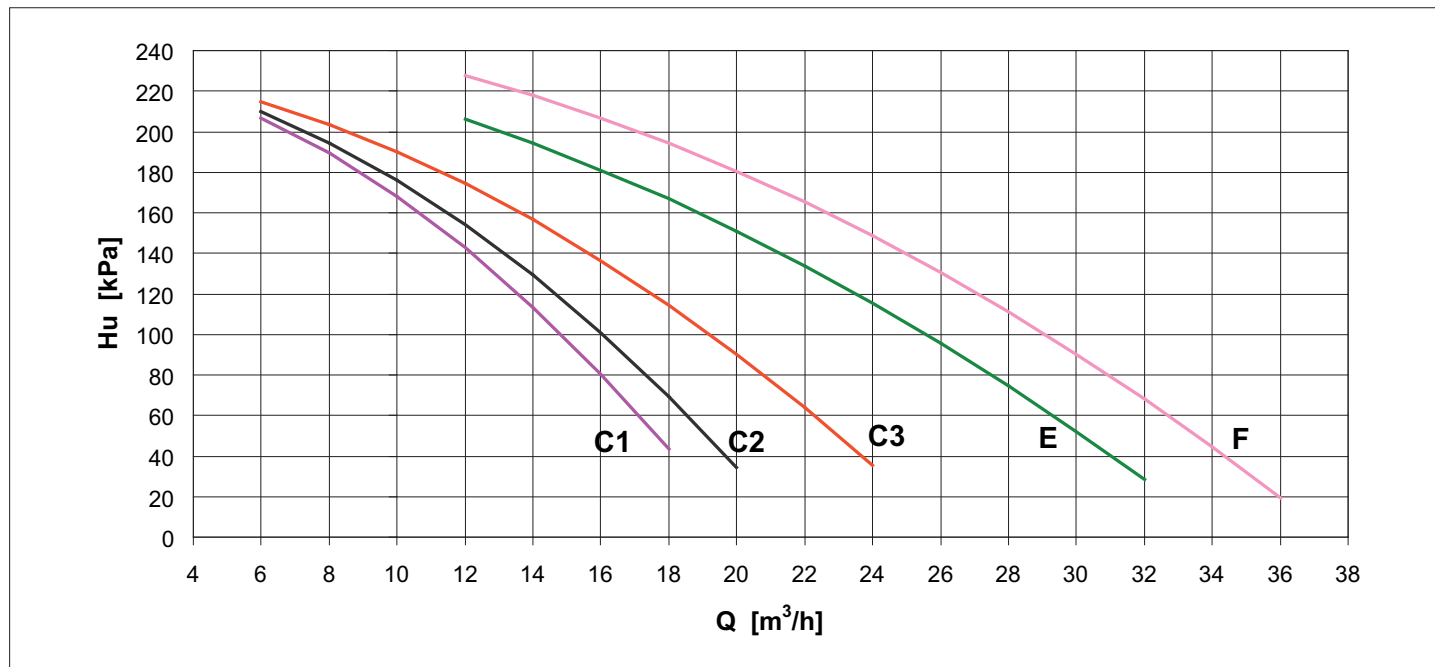

COOLING - 1 PUMP - LOW HEAD PUMP

	Pf (1)	Q (1)	Rif.	Pump	N.	F.L.I.	F.L.A.	Ks	Dps	Hu		
SIZE	[kW]	[m³/h]	Pump	type	Pole	[kW]	[A]	-	kPa	kPa	Kv3v	Kfi
0122	34,1	5,9	A1	DWC-V 300/1,1 R	2	1,1	2,5	294	10,1	129	66	109
0152	43,8	7,5	A2	DWC-V 300/1,1 R	2	1,1	2,5	217	12,3	122	66	109
0202	60,3	10,4	A3	DWC-V 300/1,1 R	2	1,1	2,5	123	13,2	109	27	79
0262	76,4	13,1	B1	DWC-V 300/1,1	2	1,1	2,5	104	18,0	140	27	79
0302	91,7	15,8	B2	DWC-V 300/1,1	2	1,1	2,5	92	22,9	120	27	79

HEATIN - 1 PUMP - LOW HEAD PUMP

	Pt (1)	Q (1)	Rif.	Pump	N.	F.L.I.	F.L.A.	Ks	Dps	Hu		
SIZE	[kW]	[m³/h]	Pump	type	Pole	[kW]	[A]	-	kPa	kPa	Kv3v	Kfi
0122	38,0	6,5	A1	DWC-V 300/1,1 R	2	1,1	2,5	294	12,6	124	66	109
0152	51,3	8,8	A2	DWC-V 300/1,1 R	2	1,1	2,5	217	16,9	112	66	109
0202	68,8	11,8	A3	DWC-V 300/1,1 R	2	1,1	2,5	123	17,2	98	27	79
0262	84,9	14,6	B1	DWC-V 300/1,1	2	1,1	2,5	104	22,2	128	27	79
0302	102,0	17,5	B2	DWC-V 300/1,1	2	1,1	2,5	92	28,3	103	27	79

(1) Values refer to rated operating conditions
 Pf Cooling capacity of unit
 Pt Heating capacity of unit
 Q Flow of water to evaporator
 F.L.I. Power absorbed by pump
 F.L.A. Current absorbed by pump

Ks Coefficients for calculating pressure drops
 Unit with hydronic unit without network filter and 3 way valve
 Kv3v Coefficients 3 way valve for calculating pressure drops
 Kfi Coefficients filter for calculating pressure drops
 Dps Total pressure drop of hydronic group
 Hu Residual hea

WORKING HEAD CURVES

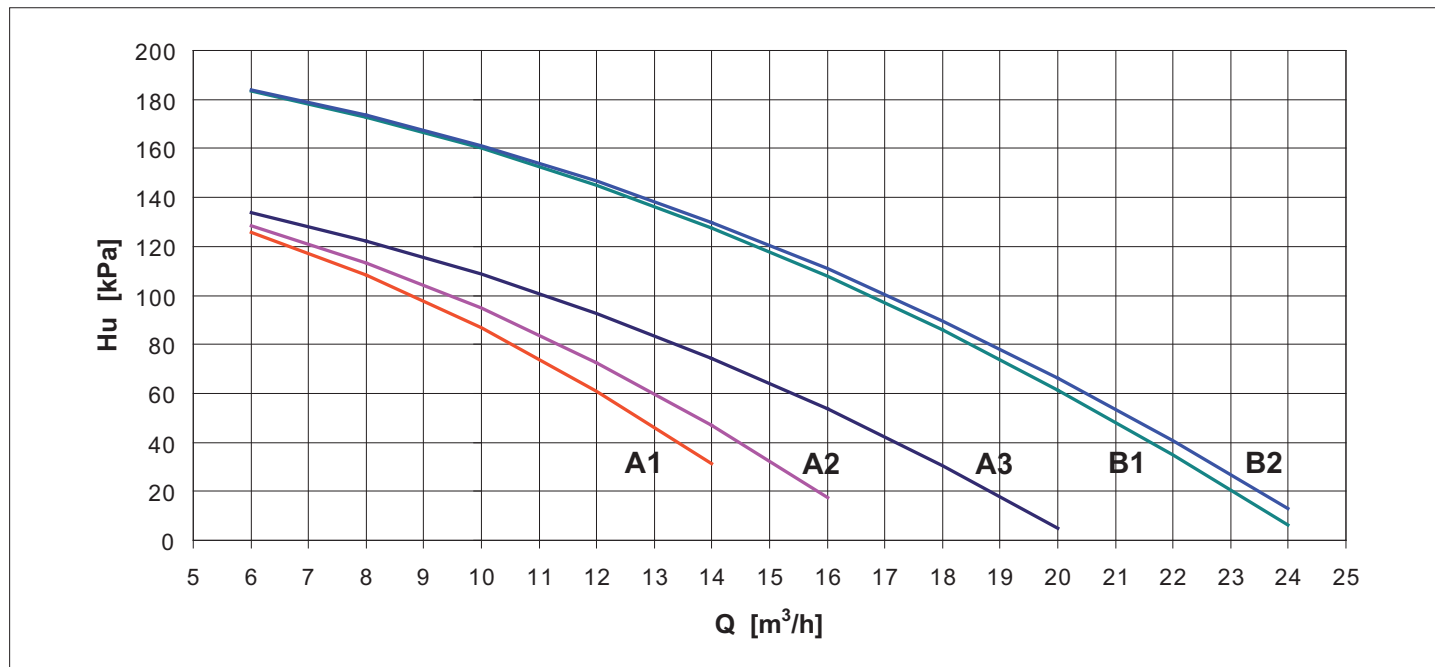

COOLING - 2 PUMPS - LOW HEAD PUMP

	Pf (1)	Q (1)	Rif.	Pump	N.	F.L.I.	F.L.A.	Ks	Dps	Hu		
SIZE	[kW]	[m³/h]	Pump	type	Pole	[kW]	[A]	-	kPa	kPa	Kv3v	Kfi
0122	34,1	5,9	A1	DWC-V 300/1,1 R	2	1,1	2,5	373	12,8	126	66	109
0152	43,8	7,5	A2	DWC-V 300/1,1 R	2	1,1	2,5	293	16,6	117	66	109
0202	60,3	10,4	A3	DWC-V 300/1,1 R	2	1,1	2,5	153	16,5	106	27	79
0262	76,4	13,1	B1	DWC-V 300/1,1	2	1,1	2,5	134	23,1	135	27	79
0302	91,7	15,8	B2	DWC-V 300/1,1	2	1,1	2,5	122	30,3	113	27	79

HEATING - 2 PUMPS - LOW HEAD PUMP

	Pt (1)	Q (1)	Rif.	Pump	N.	F.L.I.	F.L.A.	Ks	Dps	Hu		
SIZE	[kW]	[m³/h]	Pump	type	Pole	[kW]	[A]	-	kPa	kPa	Kv3v	Kfi
0122	38,0	6,5	A1	DWC-V 300/1,1 R	2	1,1	2,5	373	15,9	121	66	109
0152	51,3	8,8	A2	DWC-V 300/1,1 R	2	1,1	2,5	293	22,8	106	66	109
0202	68,8	11,8	A3	DWC-V 300/1,1 R	2	1,1	2,5	153	21,4	94	27	79
0262	84,9	14,6	B1	DWC-V 300/1,1	2	1,1	2,5	134	28,6	121	27	79
0302	102,0	17,5	B2	DWC-V 300/1,1	2	1,1	2,5	122	37,6	93	27	79

(1) Values refer to rated operating conditions
 Pf Cooling capacity of unit
 Pt Heating capacity of unit
 Q Flow of water to evaporator
 F.L.I. Power absorbed by pump
 F.L.A. Current absorbed by pump

Ks Coefficients for calculating pressure drops
 Unit with hydronic unit without network filter and 3 way valve
 Kv3v Coefficients 3 way valve for calculating pressure drops
 Kfi Coefficients filter for calculating pressure drops
 Dps Total pressure drop of hydronic group
 Hu Residual hea

WORKING HEAD CURVES

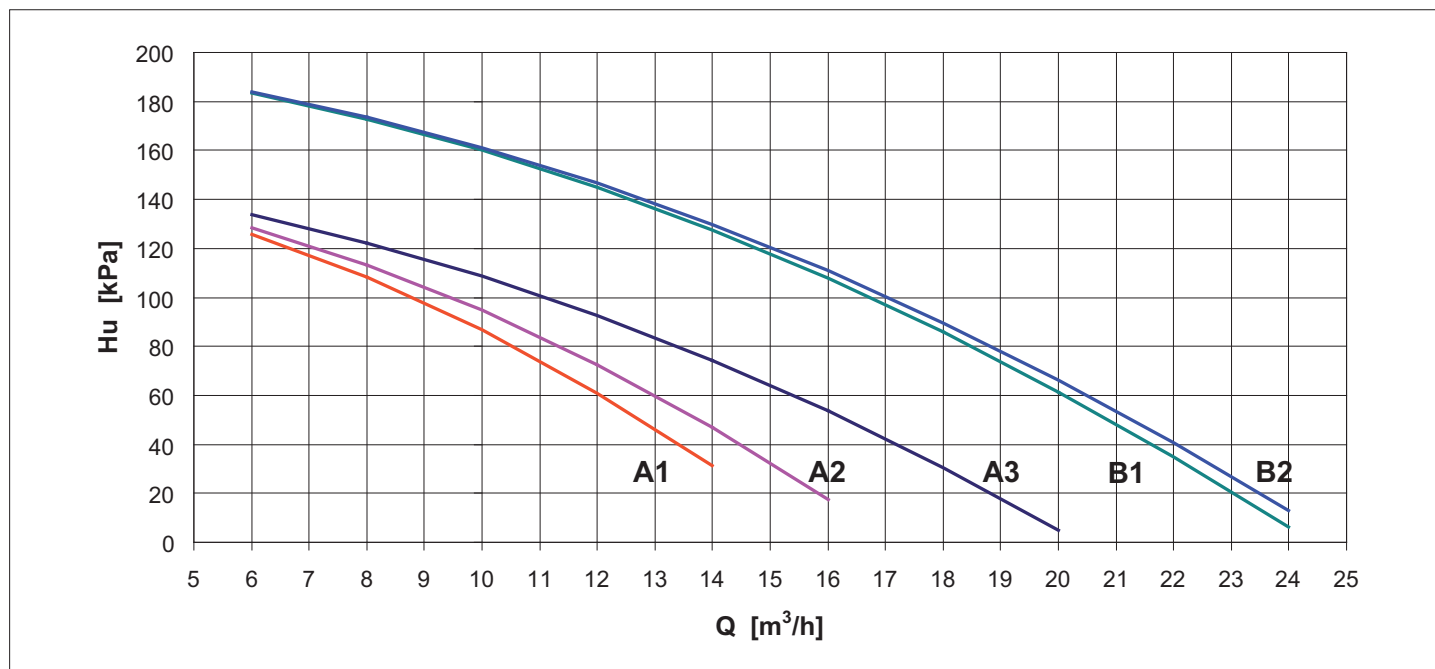

16. ELECTRICAL DATA

AWR-HT / CA-E

SIZE	Maximum values								
	Compressor				Fans (1)		Total (1) (2)		
	n	F.L.I. [kW]	F.L.A. [A]	L.R.A. [A]	F.L.I. [kW]	F.L.A. [A]	F.L.I. [kW]	F.L.A. [A]	L.R.A. [A]
0122	2	2 X 7,9	2 X 13,9	2 X 101	0,25	1,1	16,8	32,2	119,3
0152	2	2 X 10	2 X 17	2 X 99	0,25	1,1	21,5	40,6	122,6
0202	2	2 X 14,2	2 X 23,3	2 X 127	0,25	1,1	30,4	55,4	159,1
0262	2	2 X 18	2 X 28,5	2 X 167	0,25	1,1	38	65,8	204,3
0302	2	2 X 21,7	2 X 34,7	2 X 198	0,25	1,1	45,4	78,2	241,5

AWR-HT / LN-CA-E

SIZE	Maximum values								
	Compressor				Fans (1)		Total (1) (2)		
	n	F.L.I. [kW]	F.L.A. [A]	L.R.A. [A]	F.L.I. [kW]	F.L.A. [A]	F.L.I. [kW]	F.L.A. [A]	L.R.A. [A]
0122	2	2 X 7,9	2 X 13,9	2 X 101	0,25	1,1	16,8	32,2	119,3
0152	2	2 X 10	2 X 17	2 X 99	0,25	1,1	21,5	40,6	122,6
0202	2	2 X 14,2	2 X 23,3	2 X 127	0,25	1,1	30,4	55,4	159,1
0262	2	2 X 18	2 X 28,5	2 X 167	0,25	1,1	38	65,8	204,3
0302	2	2 X 21,7	2 X 34,7	2 X 198	0,25	1,1	45,4	78,2	241,5

F.L.I. Full load power

F.L.A. Full load current

L.R.A. Locked rotor amperes for single compressor

S.A. Inrush current

(1) (2) Safety values to be considered when cabling the unit for power supply and line-protections

(1) Values calculated referring to the version with the maximum number of fans working at the max absorbed current

Power supply: 400/3/50+N

Voltage tolerance: 10%

Maximum voltage unbalance: 3%

Give the typical operating conditions of units designed for outdoor installation, which can be associated (according to reference document IEC 60721) to the following classes:

- climatic conditions class 4K4H: air temperature range from -20 up to 55°C (*), relative humidity range from 4 up to 100%, with possible precipitations, at air pressure from 70 and 106 kPa and a maximum solar radiation of 1120 W/m²
- special climatic conditions negligible
- biological conditions class 4B1 and 4C2: locations in a generic urban area
- mechanically active substances class 4S2: locations in areas with sand or dust representative of urban areas
- mechanical conditions class 4M1: locations protected from significant vibrations or shocks

The required protection level for safe operation, according to reference document IEC 60529, is IP43XW (protection against access, to the most critical unit's parts, of external devices with diameter larger than 1 mm and rain).

The unit can be considered IP44XW protected, i.e. protected against access of external devices (with diameter larger than 1 mm) and water in general.

(*) for the unit's operating limits, see "selection limits" section

17. FULL LOAD SOUND LEVEL

AWR-HT / CA-E

SOUND POWER									
SIZE	Octave band [Hz]								Total sound level dB(A)
	63	125	250	500	1000	2000	4000	8000	
	Sound power level dB								
0122	89	86	83	81	81	75	70	62	84
0152	91	88	85	83	83	77	72	64	86
0202	92	89	86	84	84	78	73	65	87
0262	92	89	86	84	84	78	73	65	87
0302	92	89	86	84	84	78	73	65	87

AWR-HT / LN-CA-E

SOUND POWER									
SIZE	Octave band [Hz]								Total sound level dB(A)
	63	125	250	500	1000	2000	4000	8000	
	Sound power level dB								
0122	85	82	79	77	77	71	66	58	80
0152	87	84	81	79	79	73	68	60	82
0202	88	85	82	80	80	74	69	61	83
0262	88	85	82	80	80	74	69	61	83
0302	89	86	83	81	81	75	70	62	84

Working conditions

Ambient temperature 7 C°

Exchanger water (in/out) 40/45 C°

Sound power on the basis of measurements made in compliance with ISO 9614 and Eurovent 8/1 for Eurovent certified units; in compliance with ISO 3744 for non-certified units

Such certification refers specifically to the sound Power Level in dB(A). This is therefore the only acoustic data to be considered as binding.

AWR-HT / CA-E

SOUND PRESSURE LEVEL									
SIZE	Octave band [Hz] at 10 m								Total sound level
	63	125	250	500	1000	2000	4000	8000	
	Sound pressure level dB(A)								
0122	57	54	51	49	49	43	38	30	52
0152	59	56	53	51	51	45	40	32	54
0202	60	57	54	52	52	46	41	33	55
0262	60	57	54	52	52	46	41	33	55
0302	60	57	54	52	52	46	41	33	55

AWR-HT / LN-CA-E

SOUND PRESSURE LEVEL									
SIZE	Octave band [Hz] at 10 m								Total sound level
	63	125	250	500	1000	2000	4000	8000	
	Sound pressure level dB(A)								
0122	53	50	47	45	45	39	34	26	48
0152	55	52	49	47	47	41	36	28	50
0202	56	53	50	48	48	42	37	29	51
0262	56	53	50	48	48	42	37	29	51
0302	57	54	51	49	49	43	38	30	52

Working conditions

Ambient temperature 7 C°

Exchanger water (in/out) 40/45 C°

Sound power on the basis of measurements made in compliance with ISO 9614 and Eurovent 8/1 for Eurovent certified units; in compliance with ISO 3744 for non-certified units

18. DIMENSIONAL DRAWINGS

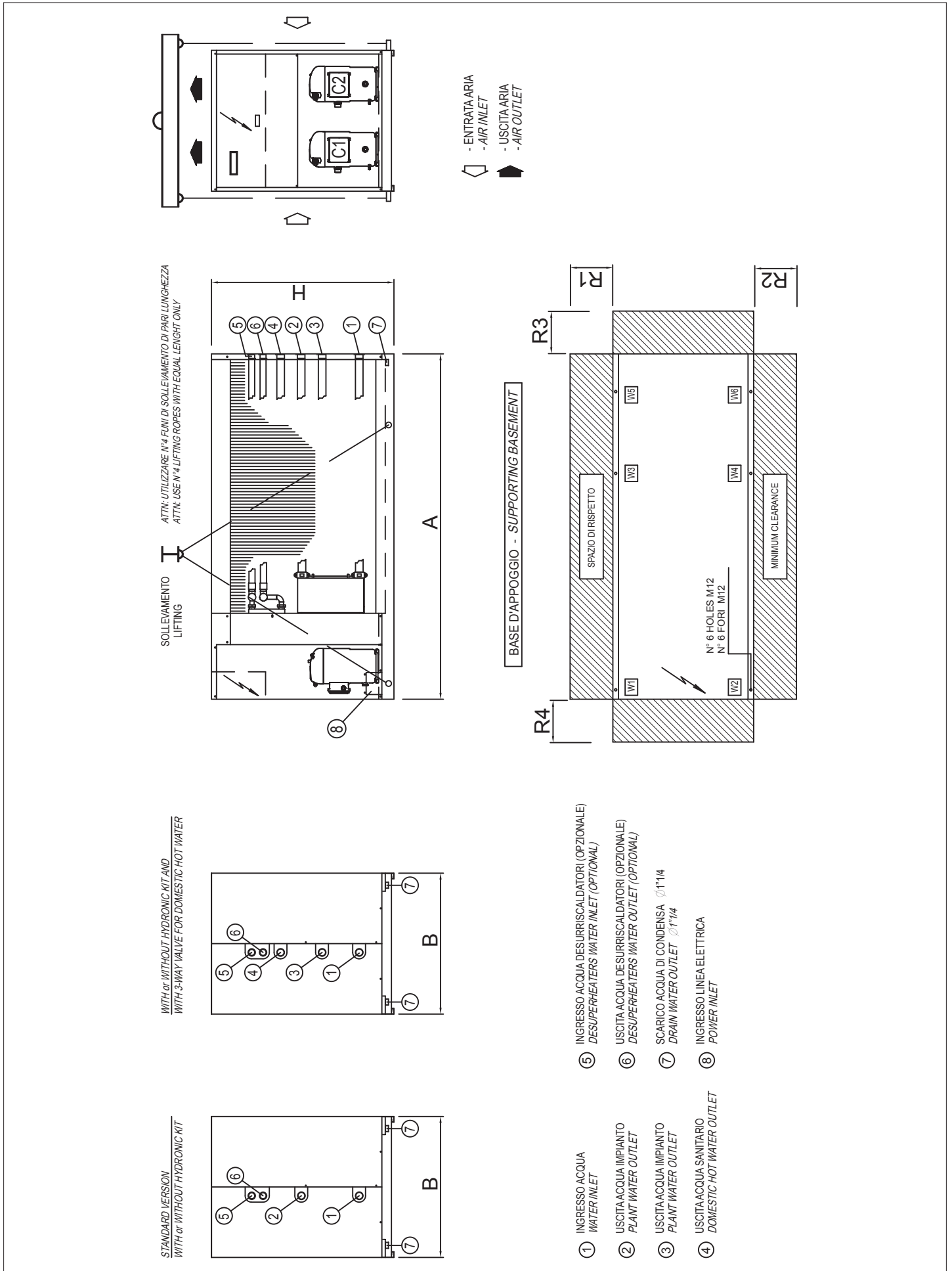

AWR-HT

SIZE	DIMENSIONS AND WEIGHTS				CLEARANCE				PLANT SIDE HEAT EXCHANGER		AUXILIARY SIDE HEAT EXCHANGER	
	A	B	H	Peso	R1	R2	R3	R4	IN/OUT		IN/OUT	
	[mm]	[mm]	[mm]	[kg]	[mm]	[mm]	[mm]	[mm]	TYPE	Ø	TYPE	Ø
AWR-HT /CA-E 0122	1695	1120	1420	510	1000	1000	600	600	GAS	1 1/2"	-	-
AWR-HT /CA-E 0152	2195	1120	1420	750	1000	1000	600	600	GAS	1 1/2"	-	-
AWR-HT /CA-E 0202	2745	1120	1420	870	1000	1000	600	600	GAS	2"	-	-
AWR-HT /CA-E 0262	2745	1120	1620	940	1000	1000	600	600	GAS	2"	-	-
AWR-HT /CA-E 0302	2745	1120	1620	1030	1000	1000	600	600	GAS	2"	-	-
AWR-HT /LN-CA-E 0122	1695	1120	1420	530	1000	1000	600	600	GAS	1 1/2"	-	-
AWR-HT /LN-CA-E 0152	2195	1120	1420	760	1000	1000	600	600	GAS	1 1/2"	-	-
AWR-HT /LN-CA-E 0202	2745	1120	1420	910	1000	1000	600	600	GAS	2"	-	-
AWR-HT /LN-CA-E 0262	2745	1120	1620	980	1000	1000	600	600	GAS	2"	-	-
AWR-HT /LN-CA-E 0302	2745	1120	1620	1030	1000	1000	600	600	GAS	2"	-	-
AWR-HT /D /CA-E 0122	1695	1120	1420	530	1000	1000	600	600	GAS	1 1/2"	GAS	1 1/2"
AWR-HT /D /CA-E 0152	2195	1120	1420	780	1000	1000	600	600	GAS	1 1/2"	GAS	1 1/2"
AWR-HT /D /CA-E 0202	2745	1120	1420	900	1000	1000	600	600	GAS	2"	GAS	1 1/2"
AWR-HT /D /CA-E 0262	2745	1120	1620	970	1000	1000	600	600	GAS	2"	GAS	1 1/2"
AWR-HT /D /CA-E 0302	2745	1120	1620	1060	1000	1000	600	600	GAS	2"	GAS	1 1/2"
AWR-HT /D /LN-CA-E 0122	1695	1120	1420	550	1000	1000	600	600	GAS	1 1/2"	GAS	1 1/2"
AWR-HT /D /LN-CA-E 0152	2195	1120	1420	780	1000	1000	600	600	GAS	1 1/2"	GAS	1 1/2"
AWR-HT /D /LN-CA-E 0202	2745	1120	1420	940	1000	1000	600	600	GAS	2"	GAS	1 1/2"
AWR-HT /D /LN-CA-E 0262	2745	1120	1620	1010	1000	1000	600	600	GAS	2"	GAS	1 1/2"
AWR-HT /D /LN-CA-E 0302	2745	1120	1620	1060	1000	1000	600	600	GAS	2"	GAS	1 1/2"

19. LEGEND OF PIPE CONNECTIONS

UNI ISO 228/1

Pipe threads where pressure-tight joints are not made on the threads - Designation, dimensions and tolerances

Used terminology:

G: Pipe threads where pressure-tight joints are not made on the threads

A: Close tolerance class for external pipe threads where pressure-tight joints are not made on the threads

B: Wider tolerance class for external pipe threads where pressure-tight joints are not made on the threads

Internal threads: G letter followed by thread mark (only tolerance class)

External threads: G letter followed by thread mark and by A letter for A class external threads or by B letter for B class external threads.

UNI ISO 7/1

Pipe threads where pressure-tight joints are made on the threads - Designation, dimensions and tolerances

Used terminology:

Rp: Internal cylindrical threads where pressure-tight joints are made on the threads

Rc: Internal conical threads where pressure-tight joints are made on the threads

R: External conical threads where pressure-tight joints are made on the threads

Internal cylindrical threads: R letter followed by p letter

Internal conical threads: R letter followed by c letter

External conical threads: R letter

Designation	Description
UNI ISO 7/1 - Rp 1 1/2	Internal cylindrical threads where pressure-tight joints are made on the threads, defined by standard UNI ISO 7/1 Conventional ø 1 1/2"
UNI ISO 7/1 - Rp 2 1/2	Internal cylindrical threads where pressure-tight joints are made on the threads, defined by standard UNI ISO 7/1 Conventional ø 2 1/2"
UNI ISO 7/1 - Rp 3	Internal cylindrical threads where pressure-tight joints are made on the threads, defined by standard UNI ISO 7/1 Conventional ø 3"
UNI ISO 7/1 - R 3	External conical threads where pressure-tight joints are made on the threads, defined by standard UNI ISO 7/1 Conventional ø 3"
UNI ISO 228/1 - G 4 B	Internal cylindrical threads where pressure-tight joints are not made on the threads, defined by standard UNI ISO 228/1 Tolerance class B for external thread Conventional ø 4"
DN 80 PN 16	Flange Nominal Diameter: 80 mm Nominal Pressure: 16 bar

Notes:

Conventional diameter value [in inches] identifies short thread designation, based upon the relative standard.

All relative values are defined by standards.

As example, here below some values:

	UNI ISO 7/1	UNI ISO 228/1
Conventional ø	1"	1"
Pitch	2.309 mm	2.309 mm
External ø	33.249 mm	33.249 mm
Core ø	30.291 mm	30.291 mm
Thread height	1.479 mm	1.479 mm

**Climaveneta S.p.A.**

Via Sarson 57/c
36061 Bassano del Grappa (VI)
Italy
Tel +39 0424 509500
Fax +39 0424 509509
info@climaveneta.com
www.climaveneta.com

Climaveneta France

3, Village d'Entreprises
ZA de la Couronne des Prés
Avenue de la Mauldre
78680 Epone
France
Tel +33 (0)1 30 95 19 19
Fax +33 (0)1 30 95 18 18
info@climaveneta.fr
www.climaveneta.fr

Climaveneta Deutschland

Rhenus Platz, 2
59439 Holzwickede
Germany
Tel +49 2301 91222-0
Fax +49 2301 91222-99
info@climaveneta.de
www.climaveneta.de

**Climaveneta
Espana - Top Clima**

Londres 67, 1° 4°
08036 Barcelona
Spain
Tel +34 963 195 600
Fax +34 963 615 167
topclima@topclima.com
www.climaveneta.com

**Climaveneta Chat Union
Refrig. Equipment Co Ltd**

88 Bai Yun Rd, Pudong Xinghuo
New dev. zone 201419 Shanghai
China
Tel 008 621 575 055 66
Fax 008 621 575 057 97

Climaveneta Polska Sp. z o.o.

Ul. Sienkiewicza 13A
05-120 Legionowo
Poland
Tel +48 22 766 34 55-57
Fax +48 22 784 39 09
info@climaveneta.pl
www.climaveneta.pl

Climaveneta India

Climate Technologies (P) LTD
#3487, 14th Main, HAL 2nd stage
Indiranagar, Bangalore 560008
India
Tel +91-80-42466900 - 949
Fax +91-80-25203540
sales@climaveneta.in



www.climaveneta.com